



OPERATOR'S GUIDE

Titan⁵
Universal Strength Tester
Model 1710/05

TestWise™
Test Analysis Software

Covering Serial Numbers
1710/05/17/1001 and upwards

James H. Heal & Co. Ltd.
Halifax, England

Publication 290-1710-05-1\$B
© 2017

Setting the Standard

Published by:

JAMES H. HEAL & CO. LTD.
RICHMOND WORKS
HALIFAX
WEST YORKSHIRE
HX3 6EP
ENGLAND

TELEPHONE +44 (0) 1422 366355
FACSIMILE +44 (0) 1422 352440

E-mail info@james-heal.co.uk
Internet <http://www.james-heal.co.uk>

© 2017

TABLE OF CONTENTS

OPERATOR'S GUIDE	1
Table of Contents.....	3
JAMES HEAL	5
Setting the Standard.....	5
Areas of Expertise	5
TITAN - UNIVERSAL STRENGTH TESTER.....	6
Installing TestWise.....	7
Recommended Specification for PC and Printer.....	7
Installing TestWise Test Analysis Software	8
Licensing Dongle	9
Licensing Dongle Installation.....	11
Software Installation.....	12
Starting TestWise for the First Time	15
User Management.....	17
TestWise Start Screen.....	19
TestWise Options and Customisation.....	21
Using Search Filters to Find a Standard	24
Your Favourite Standards in One-Click.....	26
Creating Favourite Groups for Standards	27
Quick Start	30
The Essential Elements of TestWise	30
Making Changes During the Test.....	43
Changing the Number of Specimens.....	43
Adding a Specimen	45
Delete a Specimen	46
Useful Features.....	47
Selecting Jaw Schemes	47
Show Data Points.....	49
Find Force or Find Extension.....	50
Auto Hide Panes	51
Copy Graphs, Copy Results and Export Data.....	52
Reset.....	53
Manual Control	54
Collapse and Expand	56
Using the Standards Editor	57
Creating Custom Standards	57
Setting Up a New Jaw Scheme.....	64

T19 CHECK WEIGHT SET	70
Applications	75
Tensile Strength and Elongation.....	76
Fabric – strip test	76
Fabric – grab test	80
Yarn – Skein / Hank / Lea strength	86
Fabric Tear – trouser tear test.....	89
Fabric Tear – wing-rip tear test	93
Fabric Tear – other tests	94
Seam Slippage – fixed seam opening method	95
Seam Slippage – fixed load method.....	98
Stretch & Recovery – line contact	101
Stretch & Recovery – loop bars.....	104
Button Strength.....	109
Security of Attachments	112
Ball Burst	114
Safety	116
General	116
Emergency Stop Button.....	116
Impact Protection	116
Soft Closing Jaws.....	116
Unpacking.....	117
Installation.....	119
Installation Requirements	119
Electrical supply	119
Compressed Air supply	119
Environment.....	119
Technical Specification	120
Titan ⁵ Dimensions and Weight	121
Revision History	123

JAMES HEAL

At James Heal, we are dedicated to designing and developing high precision testing instruments and test materials for physical and colour fastness testing. Our worldwide service and calibration division and expert technical assistance complement our product range, adding real value to your laboratory testing activities.

Setting the Standard

We are committed to forming close relationships and have established numerous partnerships within the textile industry, from trade and standards organizations, to test houses, customers and distribution partners.

With a heritage spanning more than 145 years, we have evolved and grown through a culture of continuous improvement, resulting in a thorough understanding of the applications, operating conditions and requirements of customers worldwide – from independent testing laboratories and test houses, to fabric suppliers, manufacturers and retailers. Using knowledge and expertise, we consistently set the industry standard through product innovation and technology, with customer and user needs, present and future, driving our technological advancements. You can be assured that with James Heal, you will always receive the highest levels of product quality and customer service. We have Agents and Distribution partners all over the globe, ensuring locally available product whenever, and wherever you need it.

Areas of Expertise

Textile: Colour Fastness

- Chlorinated Water
- Dry Cleaning
- Dry Heat
- Hot Pressing
- Laundering
- Light
- Perspiration
- Phenolic Yellowing
- Print Durability
- Rubbing
- Washing
- Water

Textile: Physical

- Abrasion
- Bursting Strength
- Compression and Puncture
- Crease and Wrinkle Recovery
- Crimp
- Drape
- Durability
- Flammability
- Mass per unit area
- Pilling and Fuzzing
- Security of Attachments
- Seam Slippage
- Shrinkage
- Snagging
- Spray Rating
- Stretch and Recovery
- Surface Deterioration
- Tear Strength
- Tensile Strength
- Washing and Drying

Non-Textile

- Bursting strength of nonwovens, plastics and medical products
- Micro-scratching of laminates, wooden, painted, automotive and high gloss surfaces
- Physical and colour fastness testing of leather
- Rubbing fastness of laminates and wooden surfaces
- Tear strength of paper and plastics
- Tensile Strength and Tear Resistance of Rubber (requires Titan "E" version)

TITAN - UNIVERSAL STRENGTH TESTER

Titan⁵ is an outstanding, fourth generation Universal Strength Tester, designed specifically for testing textiles, nonwovens and leather in various forms: yarns, fabrics, garments and security of attachments.

Innovative engineering and intuitive understanding of your needs are combined to produce an aesthetically pleasing and ergonomic instrument, with intelligent, easy-to-use [TestWise Test Analysis Software](#), an extensive range of specimen grips and a comprehensive library of international standards and retailers' own test methods.

Features and Benefits

- Compact, desk top, standards-compliant Universal Strength Tester
- Operates as standard in both tension and compression
- Extensive range of tool-free, interchangeable specimen grips
- Choice of seven (7) load cells - up to 5000N (approx. 500kg): load cells supplied in cartridge form to improve protection and to facilitate safe handling and storage
- Microsoft Windows look and feel and familiar industry specific terminology
- Single Software Package for yarn, leather, fabric and nonwovens: tensile strength, seam slippage, security of attachments, button strength, pile loop extraction, tear strength, peel bond (delamination), stretch and recovery (cyclic), ball burst, puncture and crushing
- Extensive library of pre-loaded, national and international standards and of retailers' test methods
- 'Standards Editor' making it easy to modify existing standards or create new methods
- Automatic setting of test parameters including gauge length after selection of required standard or method
- 'Three Clicks' to start testing !



Service and Calibration

- Worldwide Service
- UKAS (ISO 17025 based) Accredited Calibration Service (tension and/or compression)
- 18 Months' Warranty

Technical Assistance

- Operator Training
- Knowledge transfer
- TestWise Software Online Maintenance and User Support
- Applications Support
- Engineering Support

INSTALLING TESTWISE

Recommended Specification for PC and Printer

Computer	Personal Computer (PC). The use of Apple MACs running Windows in a Virtual Machine (VM) is not supported.
Processor	As specified or required by the operating system. (Use the "recommended" specification).
RAM (memory)	As specified or required by the operating system. (Use the "recommended" specification).
Operating System	Windows®10, Windows® 8/8.1, Windows® 7, Windows® Vista (SP2). Compatible with 32-bit or 64-bit OS where applicable. The Microsoft dotNET Framework must be installed – dotNet is part of Windows 10 and 8/8.1, and some releases of Windows 7 – TestWise will advise if required.
Graphics Card	None required.
Monitor	Minimum resolution of 1024x768 pixels.
Hard Drive	250 GB (2 GB equates to about 1 year's testing for a typical Laboratory, without archiving).
Ports	At least 2 free USB 2.0, one for communications cable, one for licensing dongle
Printer	Any Windows compatible printer can be used. Colour printer recommended but not required. PDF generation is available within TestWise, an additional "PDF printer" is not required.
Internet	Broadband – Optional, but required to take advantage of the James Heal Online Support Package.
<p><i>Please note:</i> James Heal have made every effort to ensure TestWise software is compatible with the above specification. The company cannot, however, accept responsibility for any additional or resident software which may compromise the operation of the PC or TestWise software.</p>	

Installing TestWise Test Analysis Software

TestWise is the name of the software used to control and view results from the **Titan** instrument. It is installed from the USB Licensing Dongle (USB drive). The **Titan** instrument cannot be used without **TestWise and the Licensing Dongle**.

The PC must be running Windows Vista, Windows 7, Windows 8/8.1 or Windows 10. Other operating systems or Windows running in a virtual machine (VM) are not supported. **TestWise** is optimised for Windows 7 and above.

Before installing **TestWise** ensure your dotNET Framework is up to date using the Windows Update service or visiting <http://www.microsoft.com/net/downloads>

Ensure the PC to be used to run **TestWise** and control **Titan** meets the requirements described on the previous page.

IMPORTANT LICENSING NOTE:

TestWise uses a licensing dongle. Whenever possible keep this permanently inserted into a USB port. **TestWise** will not operate unless the licensing dongle is present. Charges will apply for replacement licensing dongles.

Licensing Dongle

TestWise 2013 and later is licensed using a USB dongle.

If a valid licensing dongle is not detected TestWise will disable all functionality.

The licensing dongle must be plugged into the PC before running TestWise. It must then remain in place in the PC for TestWise to function correctly.

The licensing dongle is also a USB flash drive.



TestWise checks for the presence of a valid licensing dongle at launch and will only allow login if a valid licensing dongle is present. If it is not detected you will see:

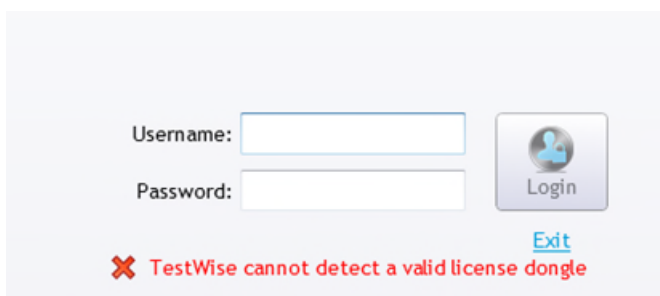

Whilst TestWise is running it also checks for the licensing dongle at random intervals. If the licensing dongle has been removed then the entire application is disabled.

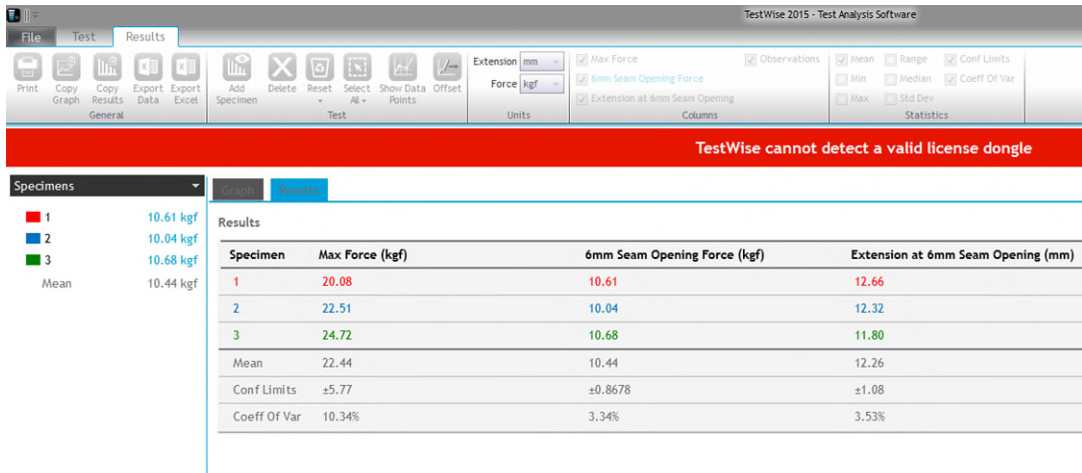

If the dongle is subsequently re-inserted it will take up to 5 seconds to be detected by TestWise and enable the interface.

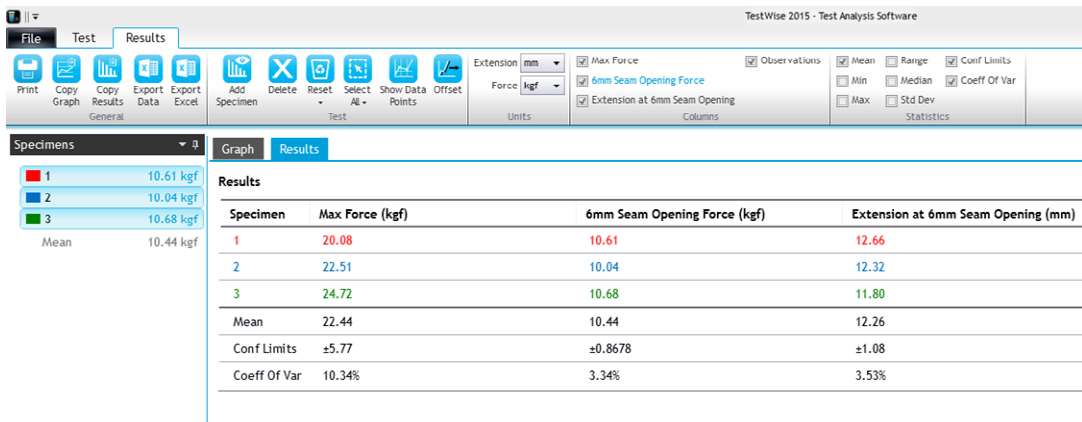

Charges will apply for replacement licensing dongles therefore please take good care of it.

Licensing Dongle Installation

Installing the licensing dongle is simple.

Before starting TestWise, insert the licensing dongle into a free USB 2.0 port.

After a few seconds the green LED will illuminate.

The driver for the licensing dongle may be installed on some operating systems.

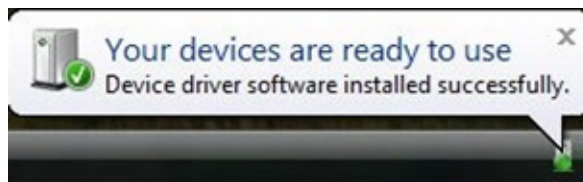
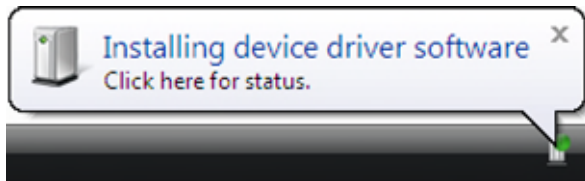

The licensing dongle is now installed.

Leave the licensing dongle permanently inserted into the USB port.

Software Installation



Insert the **TestWise** Licensing Dongle into a free USB port on the Titan PC.

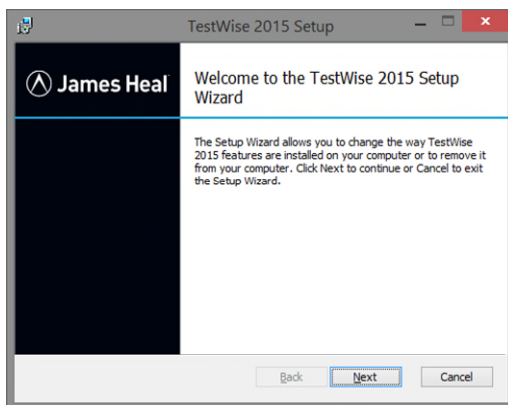

The setup will auto-run and you will first be prompted with this dialogue box.

Click **Next** to continue.

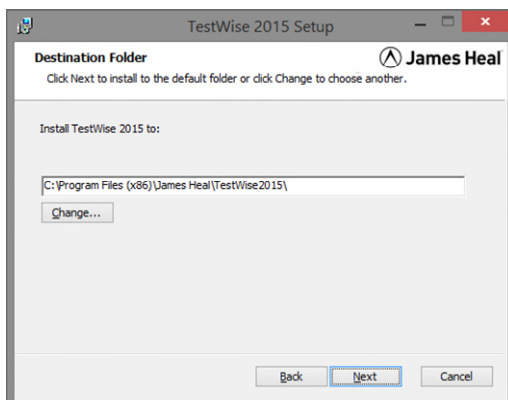

We recommend installing **TestWise** to the default location.

This is the default folder in Windows 7, 8/8.1, Vista and Windows 10.

Click **Next** to continue.

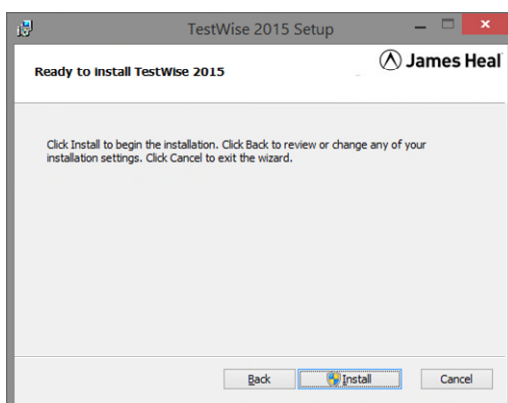

The setup procedure is now ready to install TestWise on you PC.

Click **Next** to continue.

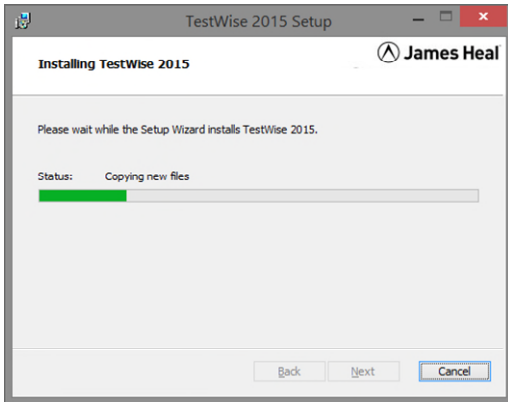

TestWise is being installed, please wait.

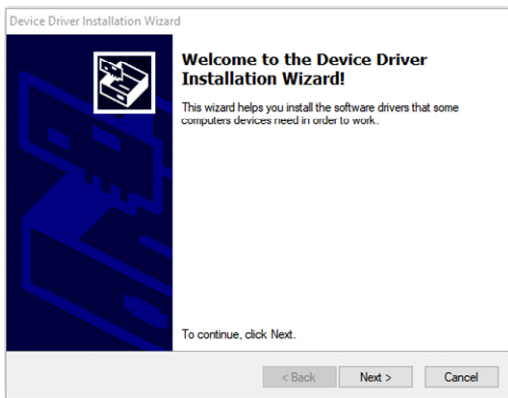

During the installation process, the TestWise installer will also run another installer for the communications driver.

Also follow the instructions and allow this driver to be installed.

Click **Next** to continue.

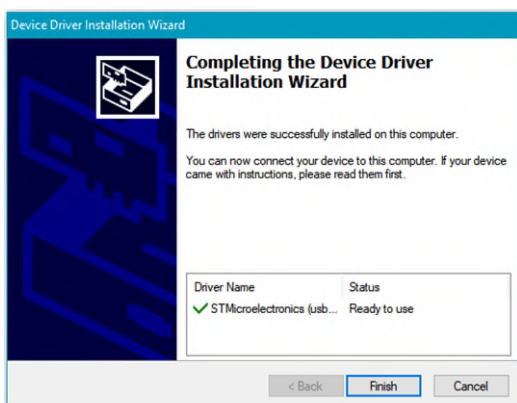
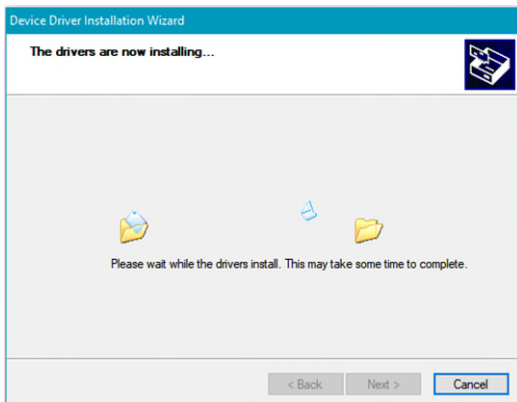

Click **Finish** to complete the installation of the driver.

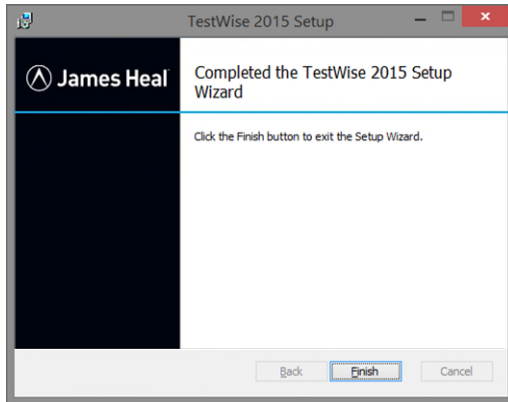

TestWise has been successfully installed.

Click **Finish**

Before attempting to run **TestWise**, please use the Windows Update service or by visiting <http://www.microsoft.com/net/downloads> to check for any updates to the Microsoft dotNET Framework if required.

You will now see the TestWise icon on your Windows Desktop.



Starting TestWise for the First Time

Before using **Titan** and **TestWise** together you must configure **TestWise** with Load Cell and Jaws Schemes data. This is a simple process which takes only a few minutes and is required only once.



Ensure the electrical power is connected and switched on, that the **Licensing Dongle** and the USB cable is connected to the PC and the **Titan** instrument.

Double-click the **TestWise** icon on your Windows Desktop to start **TestWise**.



While the **TestWise** application loads, the following splash screen displayed.



This is the first run screen.

Once this procedure is completed you will not see this again.



IMPORTANT - Please Wait for TestWise to establish a connection with Titan.

Allow **TestWise** a few moments to find the correct USB port connection for communications.

When the red text clears connection has been established.

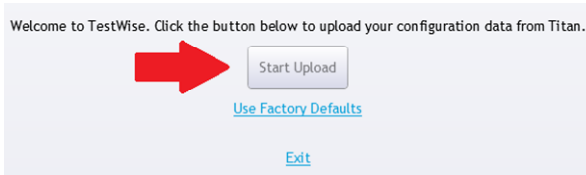

Click the **Start Upload** button to begin the upload of configuration data from **Titan**.

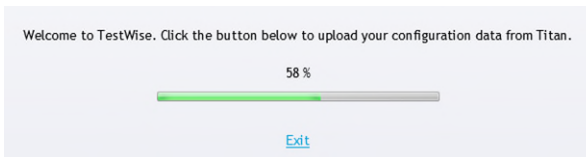

The upload of your loadcell calibration data and jaw scheme data commences. This usually takes less than 10 seconds.

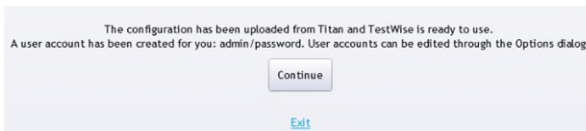

Setting up new users is detailed on the next page.

Click the **Continue** button to begin using **TestWise**.



You will then be taken to the **TestWise** main screen.

The various elements of this screen will be explained later.

User Management

TestWise creates a new user called “Admin” using a password of “password”.

We recommend you add at least one user with Administrator level and one user with Operator level.

Administrator level users can make changes to the TestWise system and make tests. Operator level users can make tests, including saving, printing and retrieval.

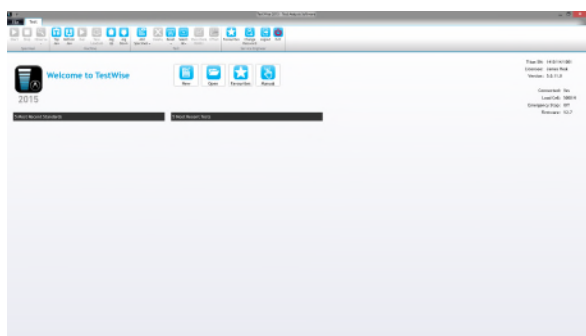

From the main screen

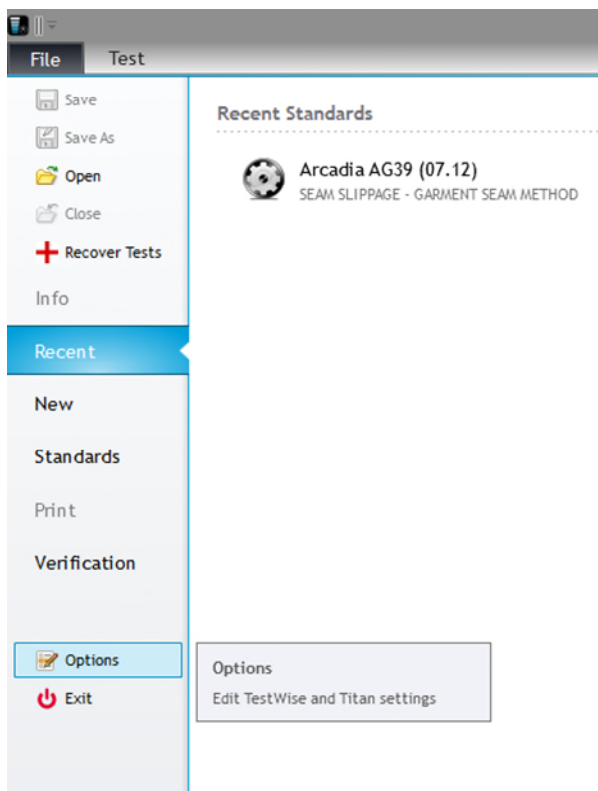

To manage users, go to File then Options.

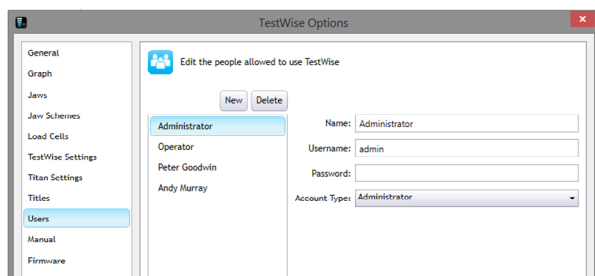

The **TestWise** Options will be displayed. Choose Users.

To create a new user, firstly click on the type of user you want to create, then click New.

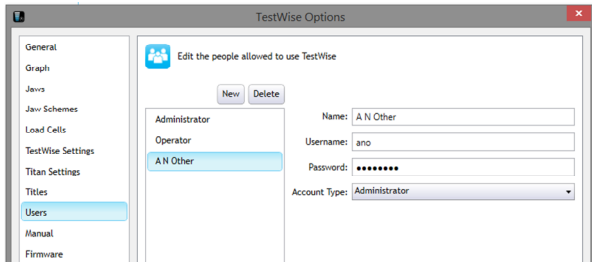

In this example we will create a user with Administrator privileges.

Enter the user details and then click Apply.

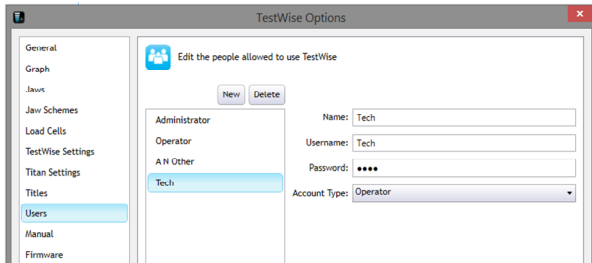

In this example we have created a user with Operator privileges.

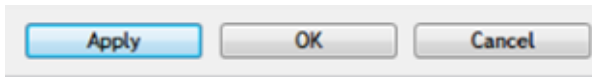

When users have been added, click Apply followed by OK.

The **TestWise** Options will close when you click OK.

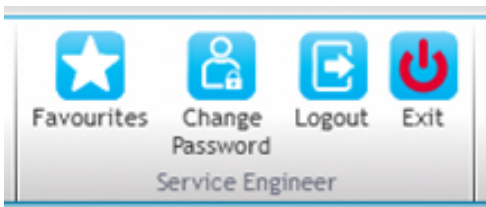

From the main screen, choose Logout.

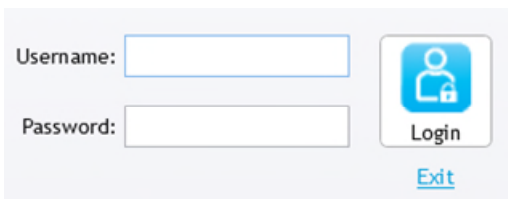

Then Login again using the users details you entered.

TestWise Start Screen

The TestWise start screen has been designed like a dash board so that the most popular tasks are easily and quickly available.

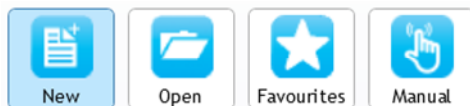
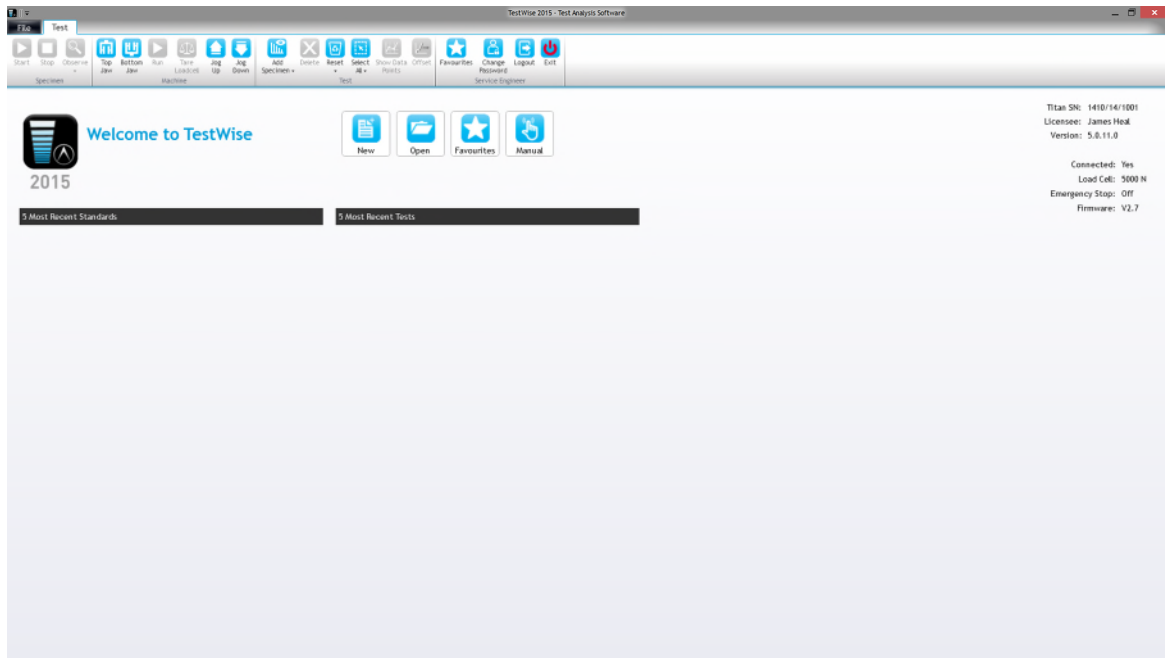

The **New** shortcut takes you to the Standard Library ready to select a standard and start a new test.

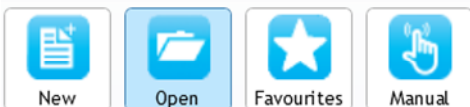

The **Open** shortcut takes you to the Open Test File dialogue. This is used to look at tests you have previously made and stored.



The **Favourites** shortcut takes you to your selected favourite standards in the Standard Library ready to select a standard and start a new test. This is a great time saver.

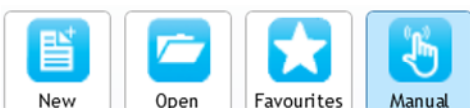

Favourites will be explained in more detail later. The **Manual** shortcut brings up a screen to allow manual control of Titan outside of the test environment.

5 Most Recent Standards

 **Arcadia AG39 (07.12)**
SEAM SLIPPAGE - GARMENT SEAM METHOD

The 5 most recently used standards are displayed. If you click the standard it will be selected ready to start a new test.

5 Most Recent Tests

 **Example Manual Seam Opening Test**
Standard: Arcadia AG39 (07.12)
File: C:\Users\pg.JHEAL\Desktop\Example Manual Seam Opening Test.xml

The 5 most recent tests are displayed. The Title of the test, the standard used and the folder location is shown.

If you click the test title, the test file will be opened.

5 Most Recent Tests

 **Trouser Tear Example #5**
Standard: EN ISO 13937-2:2000
File: C:\Test Results\Trouser Tear Example #5.xml

If the mouse is hovered over the test it is highlighted.

5 Most Recent Tests

 **Trouser Tear Example #5**
Standard: EN ISO 13937-2:2000
File: C:\Test Results\Trouser Tear Example #5.xml

Create a new test based on this one

If  is clicked then a new test based on this standard and any customisations will be setup ready to start a new test.

5 Most Recent Tests

 **Trouser Tear Example #5**
Standard: EN ISO 13937-2:2000
File: C:\Test Results\Trouser Tear Example #5.xml

Remove this item from the list

If  is clicked then this test is removed from the Most Recent list. Please note it is not deleted.

Titan SN: 1710-05/17/1001
Licensee: James Heal
Version: 7.1.20.0

Connected:
Load Cell:
Emergency Stop:
Firmware:

The top right of the TestWise start screen shows some useful information about TestWise and your Titan.

Licensee will normally display your company name.

TestWise Options and Customisation

Before you begin testing there are some Options which you should change to suit your preferences. Below are some of the options which you may like to change before you start any testing.

If you are unsure about what effect changing an option may have then we recommend not making the change, keeping the default settings.

Go to File > Options.

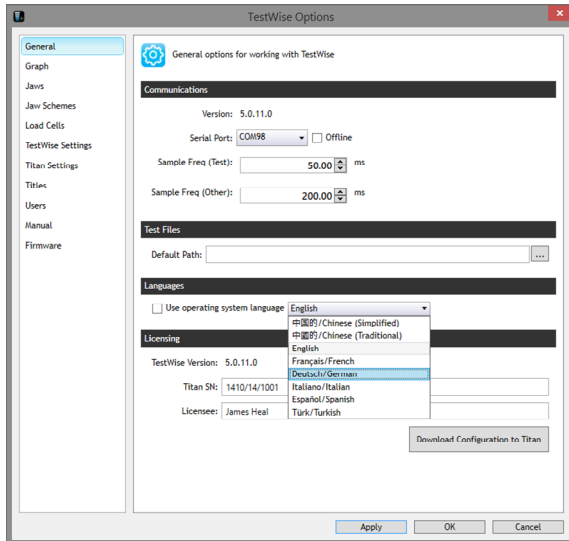

> General > Language

If you change the Language settings then you must Apply the changes and then close and re-start TestWise.

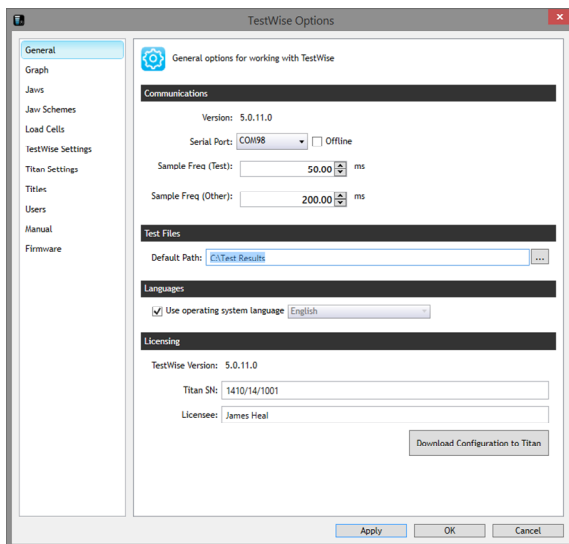

> General > Test Files

Set the preferred path to save test files.

For example, you may wish to save your test files to a network location.

Browse using the  button.

Click Apply when finished.

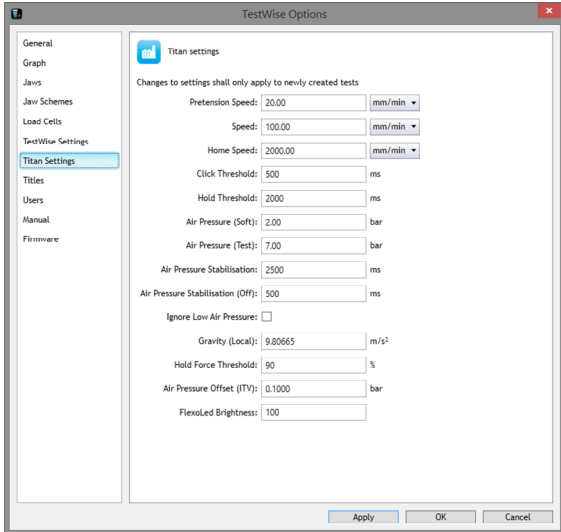

> Titan Settings

We recommend you only change these values when requested by James Heal.

If you know your Local Gravity value, enter it here, followed by Apply.

If you don't know your Local Gravity Value, do not change this value.





> Titles

These are perhaps the most practical settings as they are used in the Test Report.

The Titles are used to describe the sample/specimens.

Specify names for the test attributes

1: 

2: 

3: 

4: 

5: 

For example, you may want to change Test Name to Batch Number or Job Number.

Try to decide these Titles before you begin testing.

When finished click Apply followed by OK.

Specify names for the test attributes

1: 

2: 

3: 

4: 

5: 

Title fields can be added or removed.

Click  to remove

Click  to add another title field

 Add

– Optional Information

Test Name	
Customer	
Reference	
Material	
Comments	

Remove Add

+ Standard Customisation

Title fields can also be changed at the time of testing after the Standard has been selected.

Any changes to the Titles are also saved in the test data file.

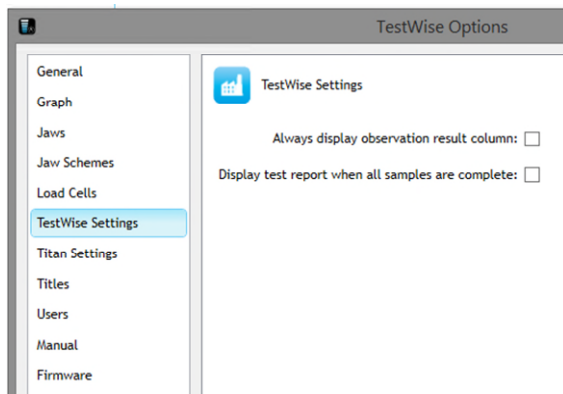

> TestWise Settings

Check these options if you would prefer them applied globally throughout TestWise.

Always display observation result column:

Display test report when all samples are complete:

If you always want Observations to be shown in the test report.

If you always want to skip the results/graph display and go straight to the test report print preview.

Using Search Filters to Find a Standard

TestWise uses a variety of search filters which enable you to quickly find the standard you need. You can simply search or use any of the special filters. Special filters reduce the standards list by Group (see Favourites later), by Test Type or by Material. The filters can be used in combination. The search is applied to both the standard reference (standard number) and the standard title. It is also possible to apply a filter on your Favourites group.

Here are some examples to illustrate searching:

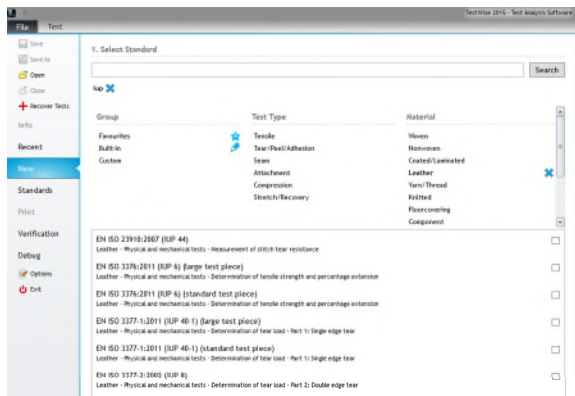

Typing *IUP* and clicking Search and also clicking Leather will find all standards with *IUP* in the reference/title which are classified as being standards for testing Leather.

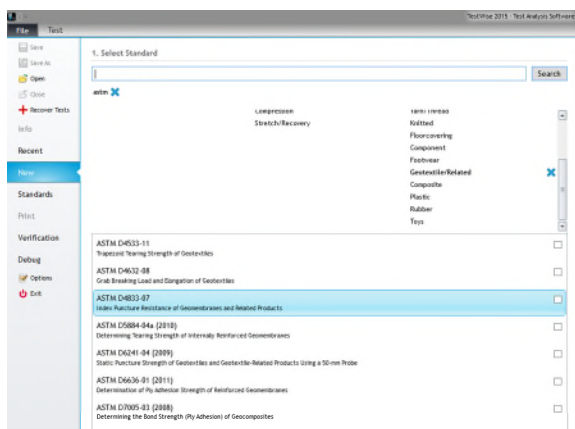

Typing *astm* and clicking Search and also clicking Tensile and Geotextile will find all standards with *astm* in the reference/title which are classified as being standards for the tensile testing of Geotextiles.

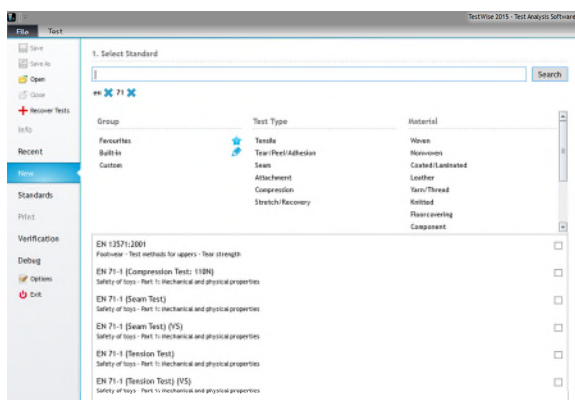

Typing *en* and *71* followed by clicking Search will find all standards with *en* and *71* in the reference/title.

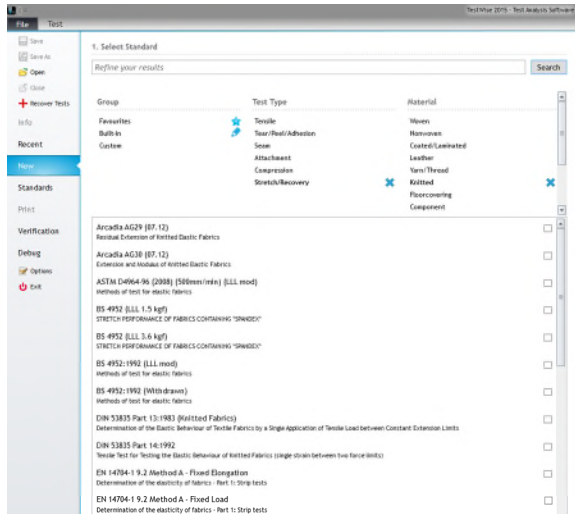

Clicking *Stretch/Recovery* and *Knitted* will find stretch & recovery standards for knitted fabrics.

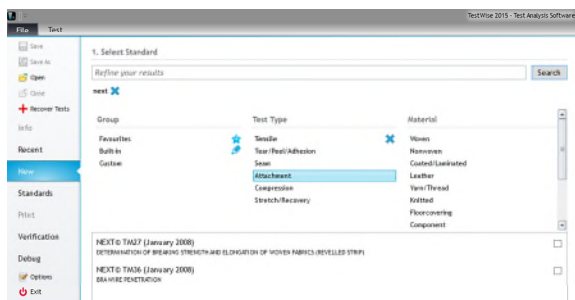

Typing *NEXT* and also clicking Tensile will find all standards with *NEXT* in the reference/title which are tensile tests.

Your Favourite Standards in One-Click

The concept of Favourites is well known when we use web browsers. In TestWise we can add or remove any standard to our Favourites group and use the Favourites shortcut to display only our favourite standards.

A collection of standards can be grouped together in a Favourites Group.

If you make a lot of tests for a specific retailer you may want to add their standards/test methods to a named Favourites Group.

Favourites are saved individually for each user.

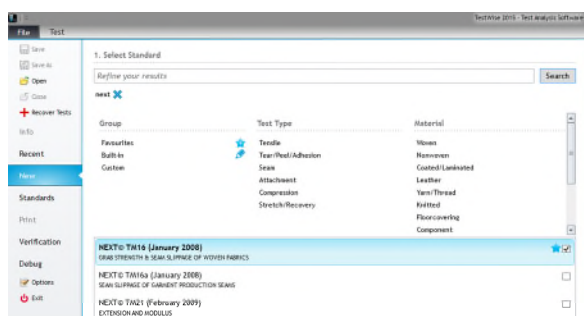

To add a standard to your Favourites group, simply check the box.

Favourites are always shown in bold and with a star.

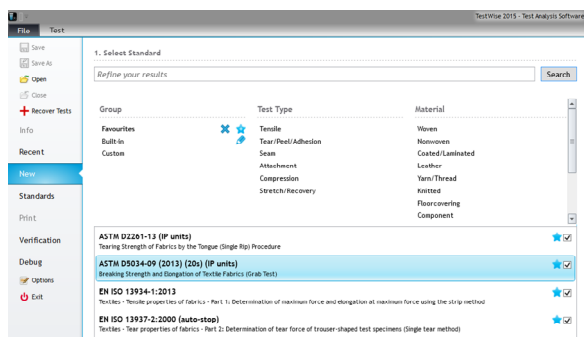

To show only your Favourites, click the Favourites group filter.

You can add or remove Favourites at any time by unchecking the box.



For example, if you wanted to select a tensile test for NEXT then would click Favourites followed by the Tensile filter.

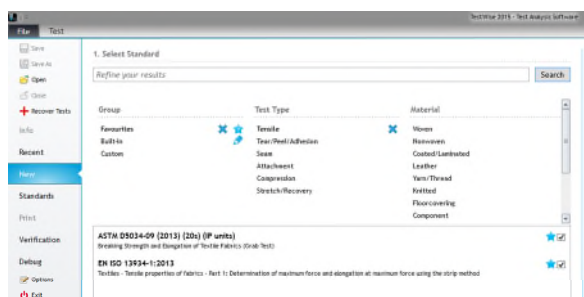

You then simply click the standard required and start testing.

Creating Favourite Groups for Standards

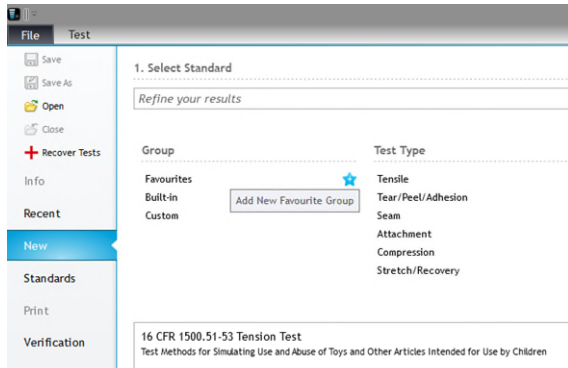

To create a new Favourites Group then click on the star+.

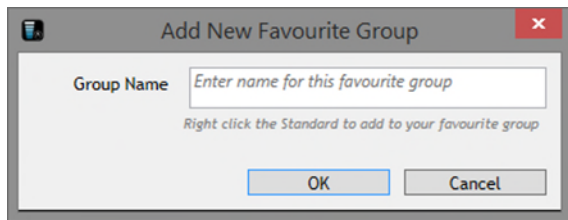

Type a name for the Favourites Group.

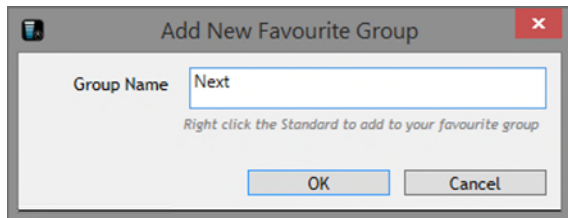

The new Favourites Group name is now shown in Groups.

Right click on any standards you want to add to the Favourites Group and then click in the box Add to Group.

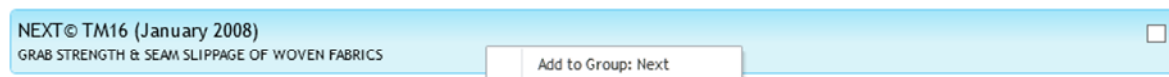

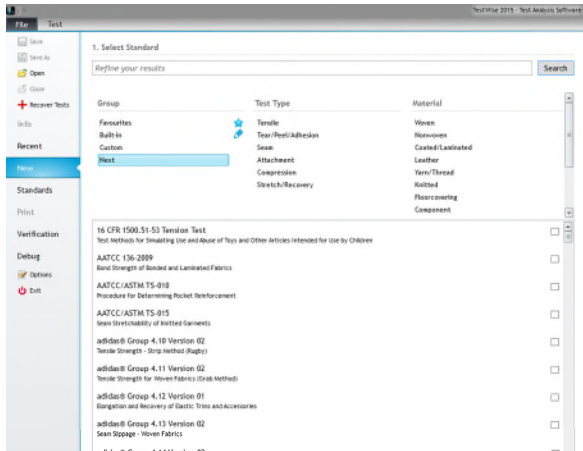

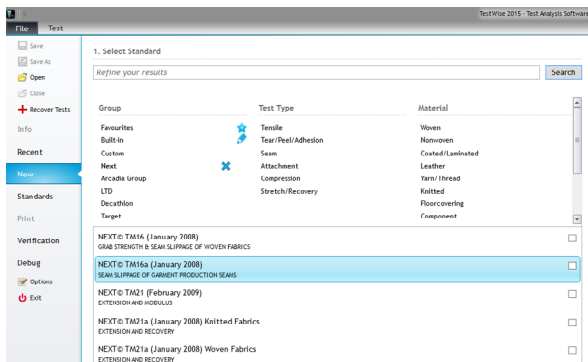

To show only the standards in the Favourites Group, click on the Favourites Group name.

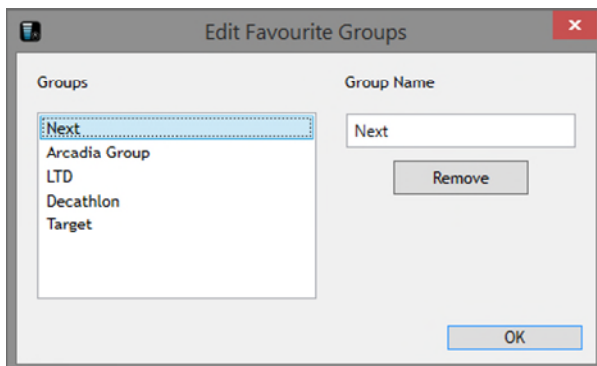

Only the standards in the Favourites Group are now listed.



To Edit a Favourites Group, either to change its name or remove (delete) the group, then click on the  icon and select the group name.

INTRODUCTION TO T27 PNEUMATIC GRIPS

T27 Pneumatic Grips can be used up to 5000N.

Typical uses include tensile strength, tear strength and seam slippage tests.

T27 is supplied as a pair of grips, complete with 4 of 100 x 30 mm rubber jaw faces and 2 of 25 mm x 25 mm rubber jaw faces.

25 mm x 25 mm are typically used for grab tensile and seam tests.

The rear jaw face is pneumatically actuated while the front jaw face is static.

The position of the front jaw can be adjusted using the knurled knob dependent upon the thickness of the specimen.



To change a jaw face, simply pull to the side and it will be released.

Slide the alternative jaw face over the dove-tail and ensure it locates correctly on the ball.

QUICK START

The Essential Elements of TestWise

The following section will guide you quickly through the simple steps of carrying out a tensile strength test on a woven fabric and illustrate the use of the essential features.

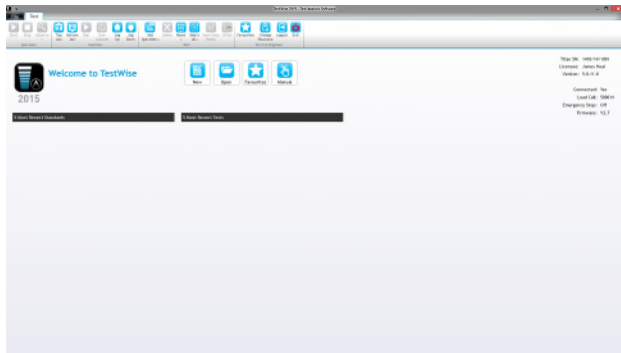

Login to **TestWise**.

Click the **New** button.

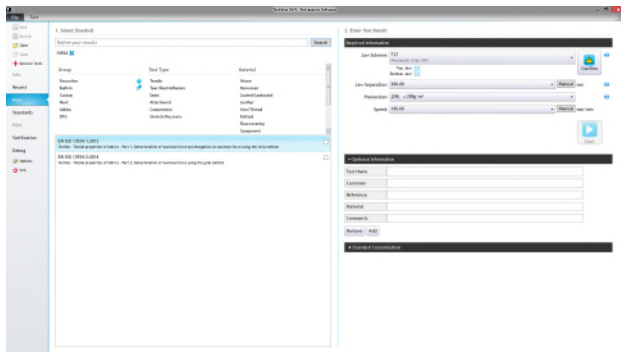

Use the search filters to locate the Standard you require.

For this example we will select EN ISO 13934-1 with a 200mm Jaw Separation.

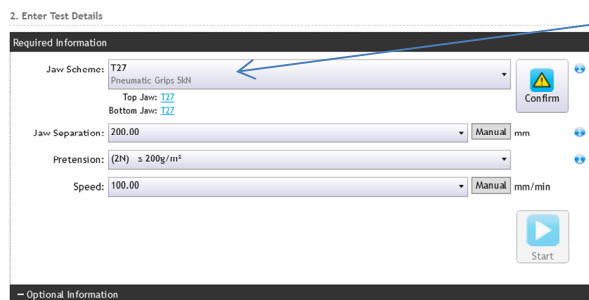

Select a suitable Jaw Scheme, in this case T27.

It is important that the selected Jaw Scheme matches the Jaws actually fitted to Titan. If they do not match then the Jaw Separation will be incorrect or damage to the instrument could occur.

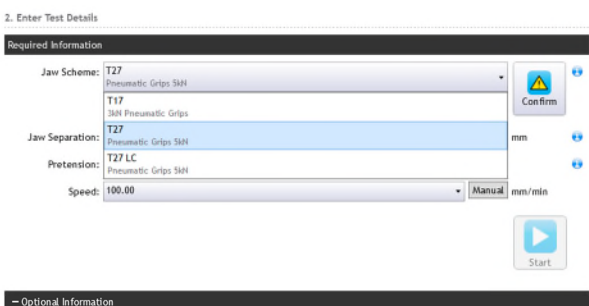

Change the Jaw Scheme by selecting from the drop down list.

2. Enter Test Details



Hovering the mouse over **T27** will show you an image of which grips or fixtures you have selected.

The image will stay on screen for 5 seconds.

2. Enter Test Details



Click the Confirm button to enable the Start button.

2. Enter Test Details



The Start button is enabled.

2. Enter Test Details

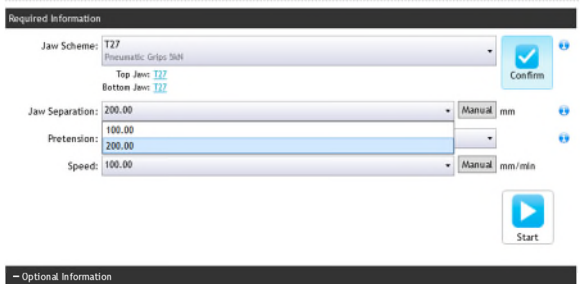

The Jaw Separation can be changed if required.

The default setting is 200mm.

100mm is used for stiff fabrics.

2. Enter Test Details

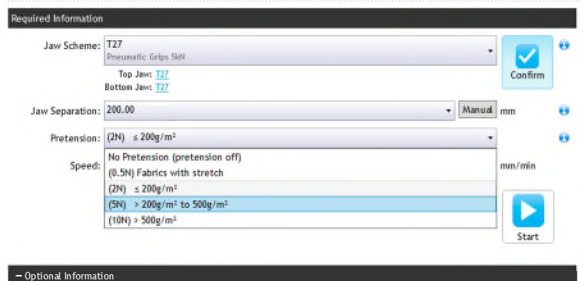

If required, select the required Pretension force, determined by the weight of the fabric (area mass).

2. Enter Test Details

Required Information

Jaw Scheme: T27
Pneumatic Grips 5kN
Top Jaw: T27
Bottom Jaw: T27

Jaw Separation: 200.00 Manual mm

Pretension: (2N) ± 200g/m²

Speed: 100.00 Manual mm/min

100.00
20.00

Confirm

Start

Optional Information

Select the Speed required.

In this case, the common default speed is 100 mm/min. However, some tests require a slower speed of 20 mm/min.

2. Enter Test Details

Required Information

Jaw Scheme: T27
Pneumatic Grips 5kN
Top Jaw: T27
Bottom Jaw: T27

Jaw Separation: 200.00 Manual mm

Pretension: (2N) ± 200g/m²

Speed: 304.8 Manual mm/min

Manual

Confirm

Start

Optional Information

If a non-standard speed is required, click Manual and type in the required speed.

Click Manual again to revert to standard speed selection.

Optional Information

Test Name	Example Tensile Test
Customer	ABC Fabrics Ltd
Reference	P0123456789
Material	100% Cotton twill
Comments	Dyed and Finished

Remove Add

Enter details which describe the sample. This information will be stored with the test results and printed on the Test Report.

These fields can be left blank and populated at any time via File > Info > Edit.

See below.

TestWise 2013 - Test Analysis Software

File Test Results

Save Save As Open Close

Info

Recent New Standards Print Options Exit

Test Details

Test Name: Example Tensile Test
Customer: ABC Fabrics
Reference: P0123456789
Material: CP6020
Comments: Bleached Only
Specimens: 5
Required Directions: Both
Jaw Scheme: T17
Jaw Separation: 200.00 mm
Load Cell: 600 N
Load Cell SN: 696456
Version: 2.5.9.0
Firmware: V2.3
Tested by: Peter Goodwin

Edit

Procedure Details

Break Detection: 10 %

Pretension

Applies a pretension force to the material

Pretension: 2.00 N

Pull To Load Cell Maximum

Pulls the material until the operator stops the test or the load cell limit is reached

Speed: 100.00 mm/min

This information can be edited at any time.

After making any changes, click Apply.

To exit without saving changes, click Cancel.

— Standard Customisation

Number of Specimens:

Directions:

Break Detection: %



Standard Customisation can be used to change some aspects of the test such as the number of specimens tested (assumed to be the same number on both directions), which directions are tested, Break Detection.

Titan automatically detects a break when a percentage force drop greater than or equal to the Break Detection value occurs.

To commence the test, click Start.



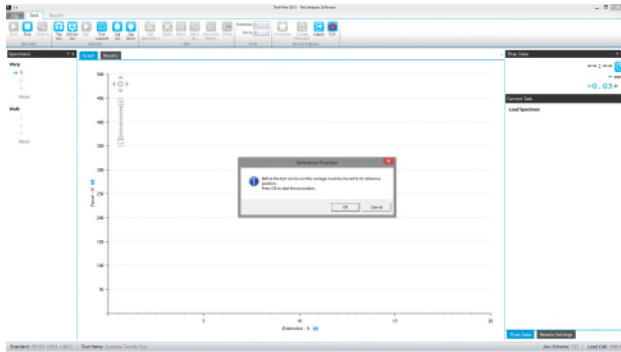

Click Start or press the F9 function key.

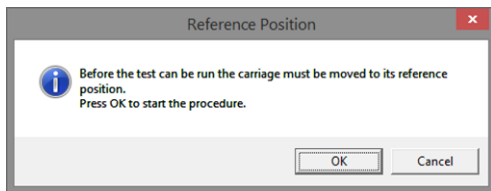

If **Titan** has been switched off, then you will be prompted to set the Reference Position. Click OK and the Carriage will move to the Home Position (the top of the column) and then return to the required Jaw Separation.

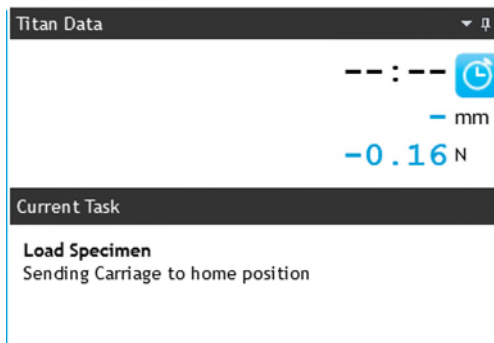

The carriage moves to the top reference position.

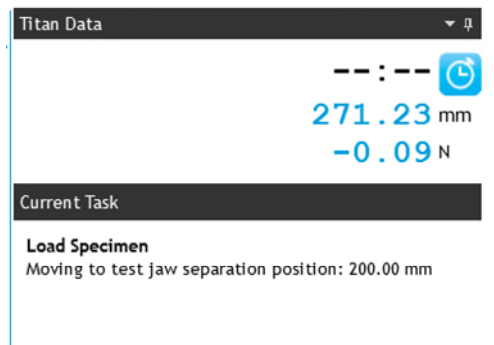

Once the reference position has been reached, the carriage will then return to the test position.

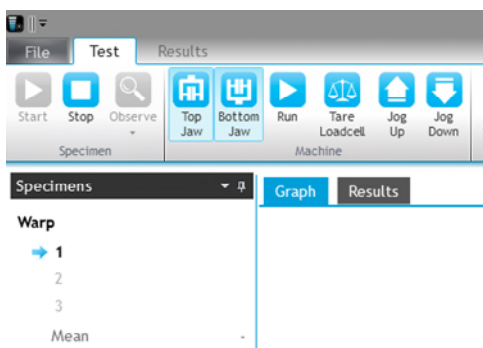

Pneumatic Jaws can be opened or closed by:

- Clicking Top Jaw on screen
- Pressing F3/F2 on the keyboard
- Pressing the Titan Start Button once
- Pressing the Foot Pedal

Place the specimen centrally in the top jaw and close.

Place the specimen centrally in the bottom jaw and without tensioning the specimen, close the bottom jaw

If while loading the specimen into the jaws you make a mistake (for example, the specimen is not central) you can open the jaw by clicking the appropriate button on screen, pressing F2 or F3 on the keyboard.

Alternatively, if you press and hold the Titan Start Button or the Foot Pedal for 2 seconds or more then the last jaw action will be undone.

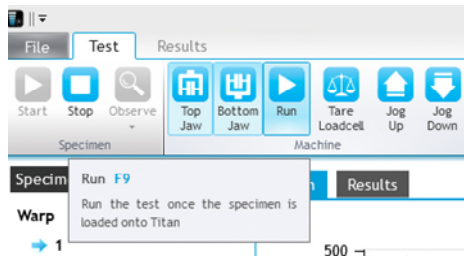

Click Run or press F9 on the keyboard to start the test.

Note that the purpose of the Function Keys changes dependent upon the task being undertaken.

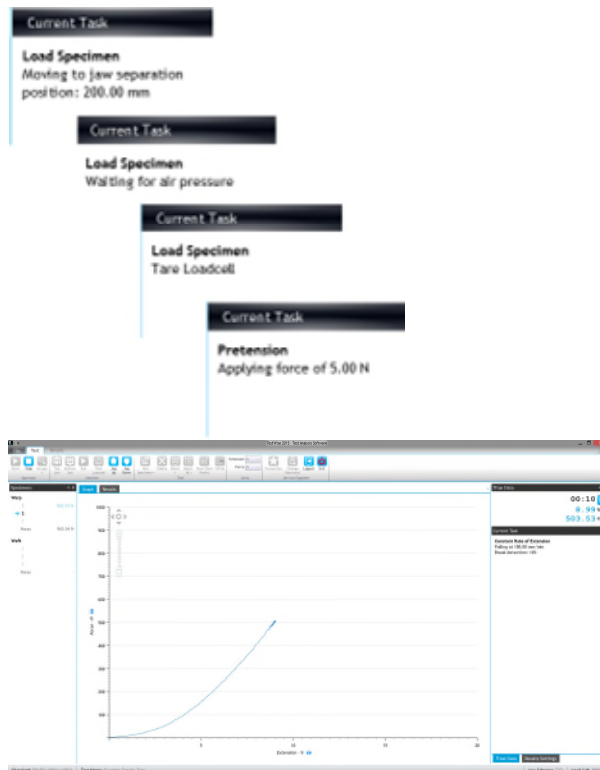

On the right hand side of the **TestWise** screen you will see a notifications of the Current Task.

Throughout the test this can change many times and these are some of the more common examples.

This is a specimen in progress.

If the plot goes off scale on either axis then the graph will rescale in real time.

You can also see an area called Titan Data. This is displaying elapsed time, extension and force. The units are dictated by the Standard by default but can be changed if required.

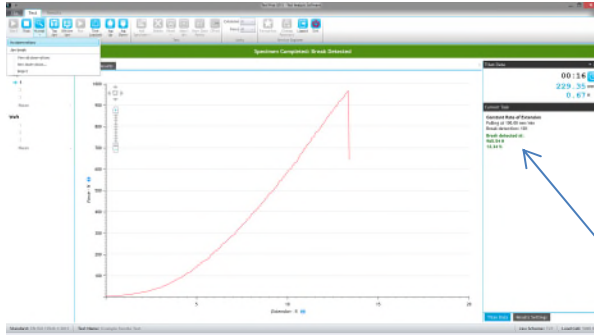

In this example of a tensile strength test we are using the Break Detection feature.

This means the specimen break is detected automatically. When this occurs the test will end and if pneumatic jaws are being used, they will open.

The Current Task now shows the Force and Extension (green text).

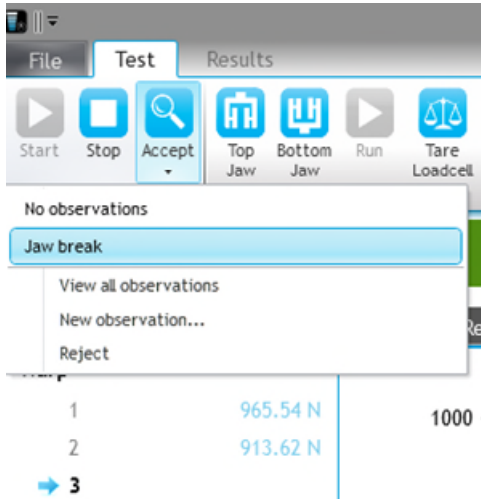

The user now Accepts the test, with or without Observations.

Accepting saves the data and then moves on ready for the next specimen.

At this stage the test can also be rejected.

Specimens can also be deleted later.

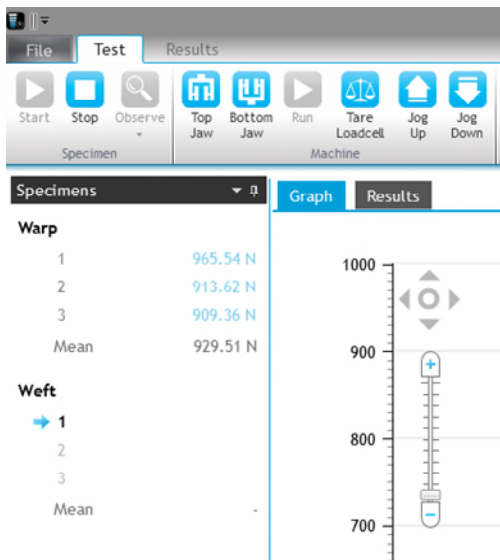

As you proceed through the test specimens you will see the test results accumulating on the left hand side of the **TestWise** screen. For convenience the mean (average) result is also shown.

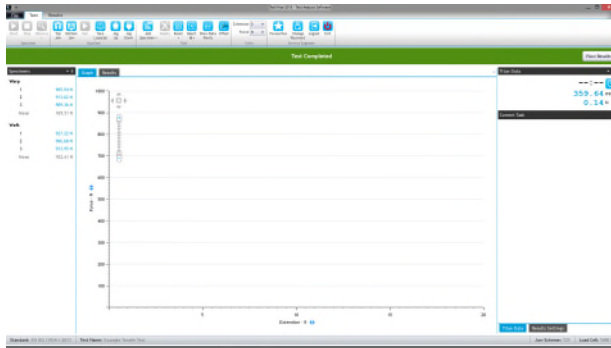

When all specimens have been completed, the green banner advises you “Test Completed”.

To see the Results, click the View Results button in the green banner.

Clicking View Results is a time saving shortcut. All the specimens will be selected for statistical calculations.



You can also click the Results tab but this does not automatically select specimens.

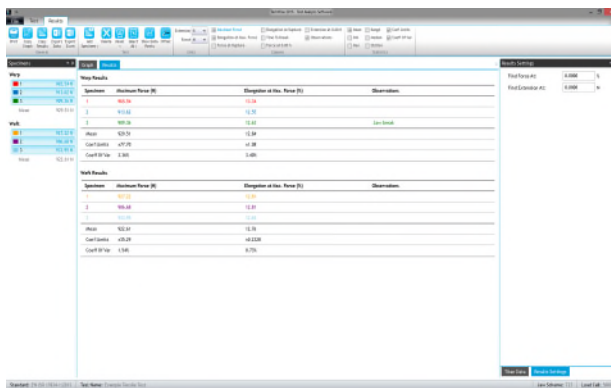

Each specimen is assigned a colour as shown here. For example, the red graph corresponds to the red results.

Up to ten (10) colours can be defined. If you have more than ten (10) specimens, the colours start again from the beginning.

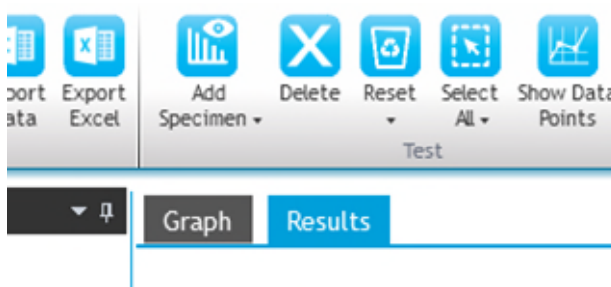

To switch between displaying Results or Graphs, click the Results or Graph tab.



Click Offset on the Ribbon and this dialog is shown. Type in a suitable value. To cancel the Offset, click Offset again.

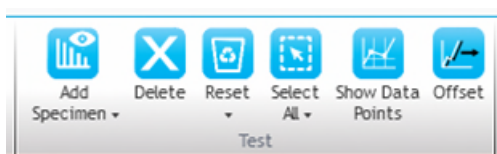

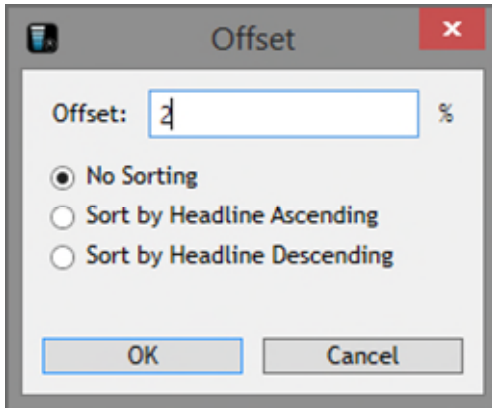

Enter an extension value to offset the curves.

Curves can also be sorted in ascending or descending order.

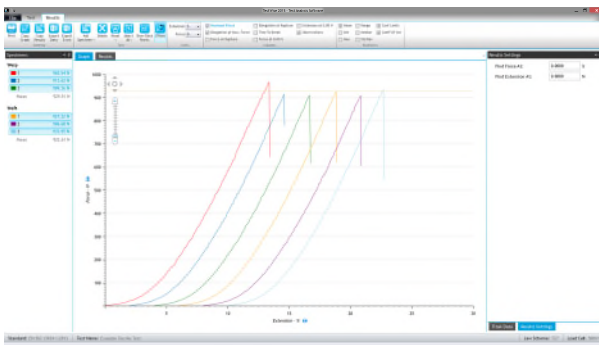

Here are the results with the graphs offset. This is useful when comparing the shape of the curves.

Elongation at Max. Force (%)	Observations
13.34	
12.55	
12.63	Jaw break

To add Observations check the box on the Ribbon.

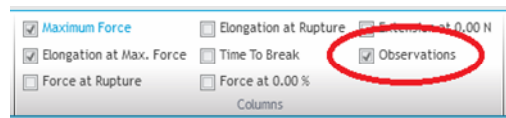

Elongation at Max. Force (%)	Observations
13.34	No observations
12.55	No observations
12.63	Jaw break
12.84	
±1.08	
3.40%	

To display any additional Statistics, check the boxes in the Ribbon. As soon as the box is checked (or unchecked) the statistics will update.

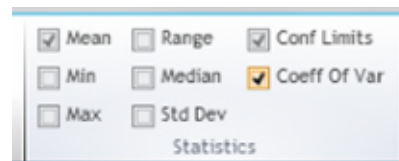

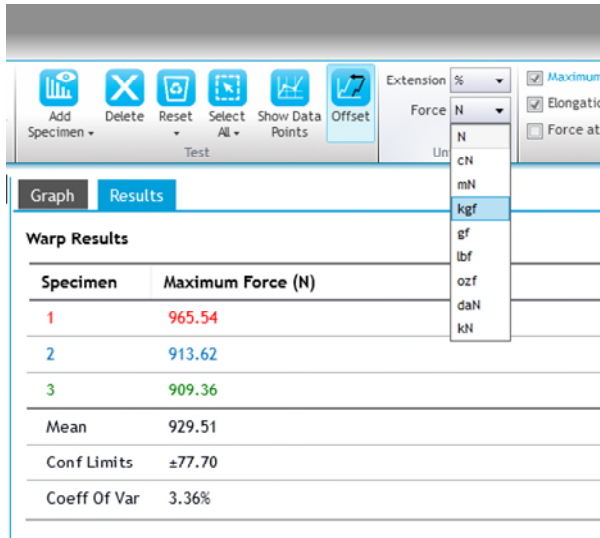

To change the force units ...

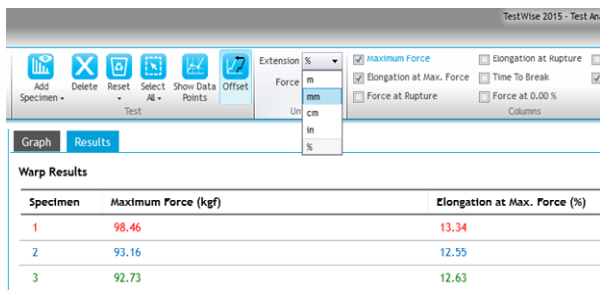

To change the extension units ...

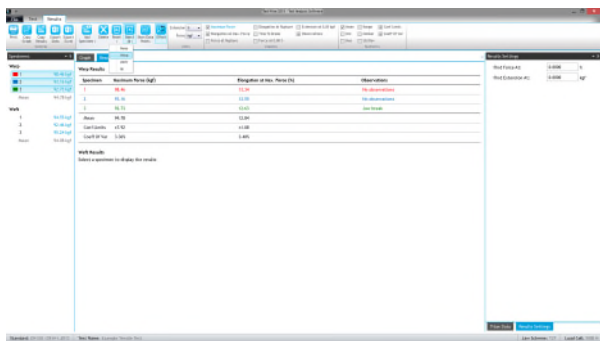

To select only one direction ...

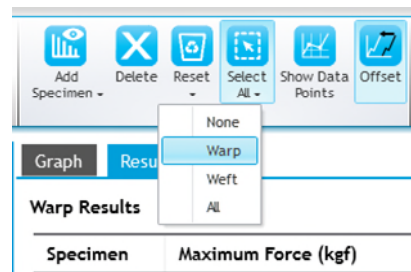

You can select a range of specimens by clicking on the first and shift-clicking on the last.

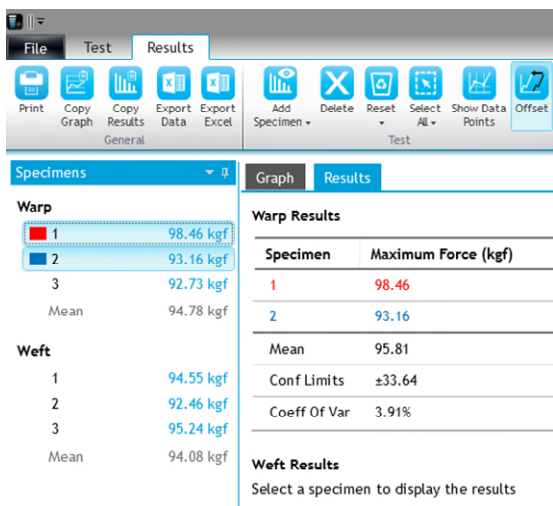

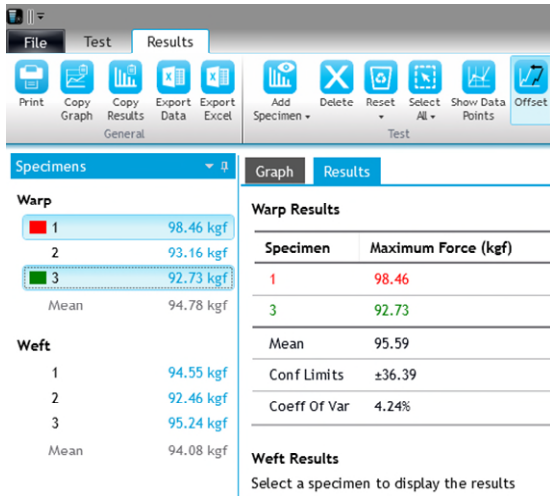

To select a discontinuous range use control-click, that is, click on each specimen while also holding down the control (CTRL) key.

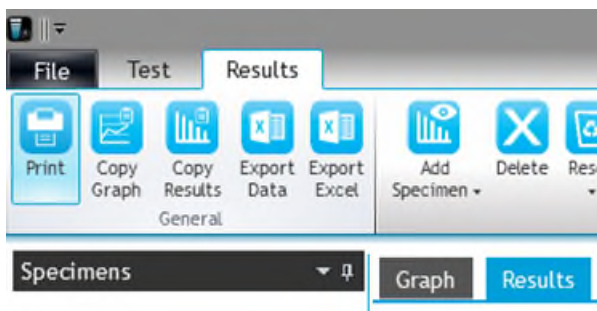

To view the Test Report, click Print. This will take you to the Print Preview.

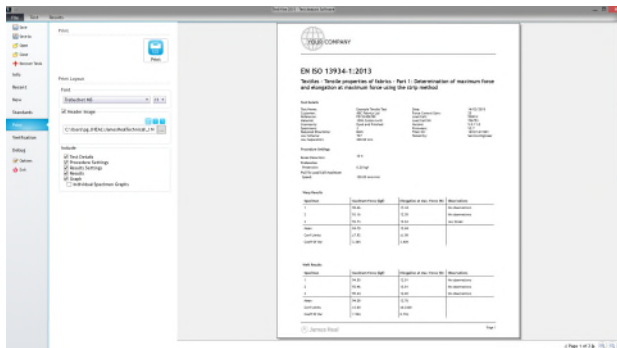

You can change:

- the default font and size
- add a logo
- choose the details in the Test Report
- change the view
- print a hard copy or PDF

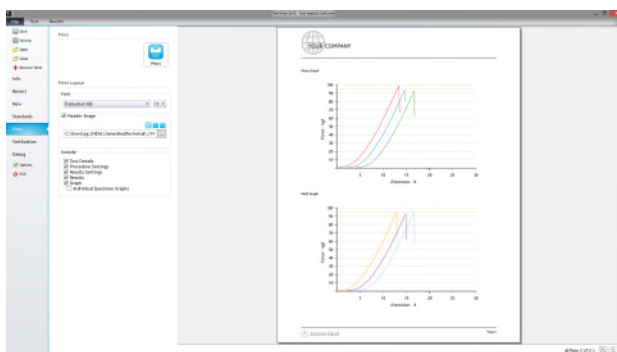

Another view.

Note the page and zoom controls here.



Another view.



Clicking Print will now bring up the Windows Print dialog.

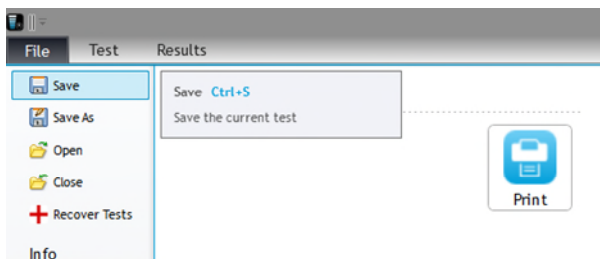
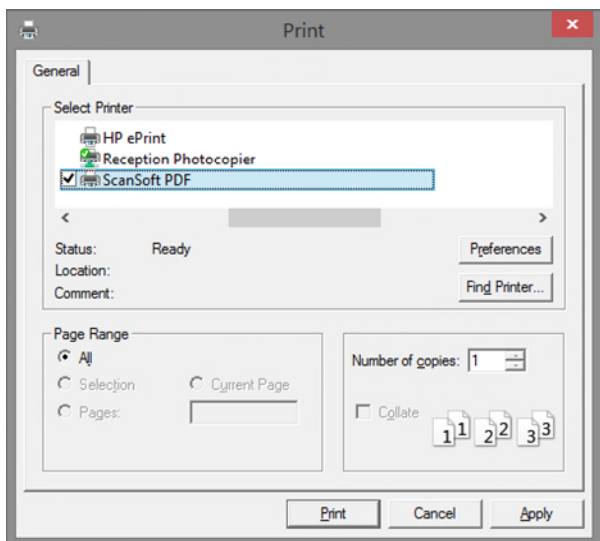

To Save the test data, select Save, Save As or Close from the File menu.

If you choose Save or Save As, the save dialogue will be displayed.

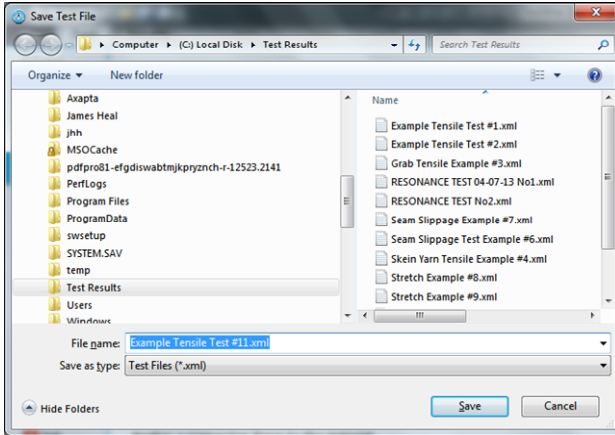

If a Default Path is defined (see Before You Begin Testing !) then this folder will be opened.

If required, edit the File Name, and then click Save.

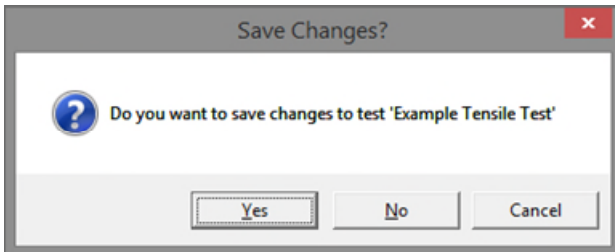

If you choose Close you will be asked if you would like to save the test.

The default response is “Yes”.

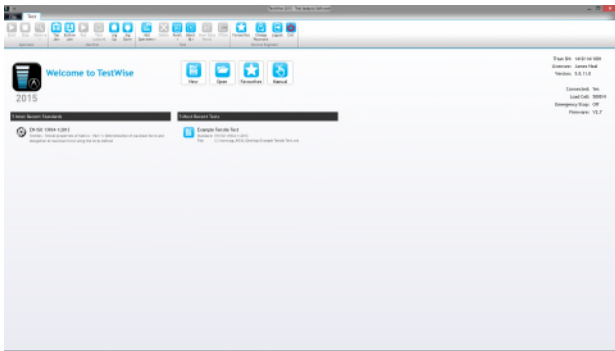

TestWise returns to the Welcome screen.

You can see the most recent standard and Results.

Congratulations !

You have now completed your first test using **Titan** and **TestWise**.

MAKING CHANGES DURING THE TEST

During a test it is sometimes necessary to change some of the details. This could be changing the number of specimens to be tested, deleting a specimen, adding a specimen, changing the break detection setting or changing the sample description or references (titles). This section shows how these changes can be made.

Changing the Number of Specimens

- Optional Information	
Test Name	Example Tensile Test
Customer	ABC Fabrics Ltd
Reference	P0123456789
Material	100% Cotton twill
Comments	Dyed and Finished
Remove	Add

The Optional Information (or titles) can be added either at the start of the test or any time after.



By default, the selected Standard requires 5 specimens to be tested in each direction.

To change the number of specimens, press F12 or click Stop.

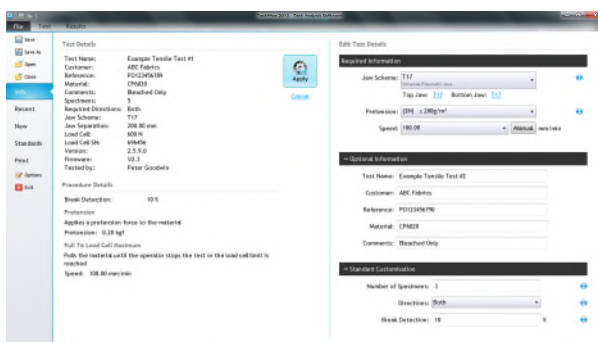

Click File > Info

The test details will be displayed.

Edit the number of Specimens (and any other details) then click Apply.



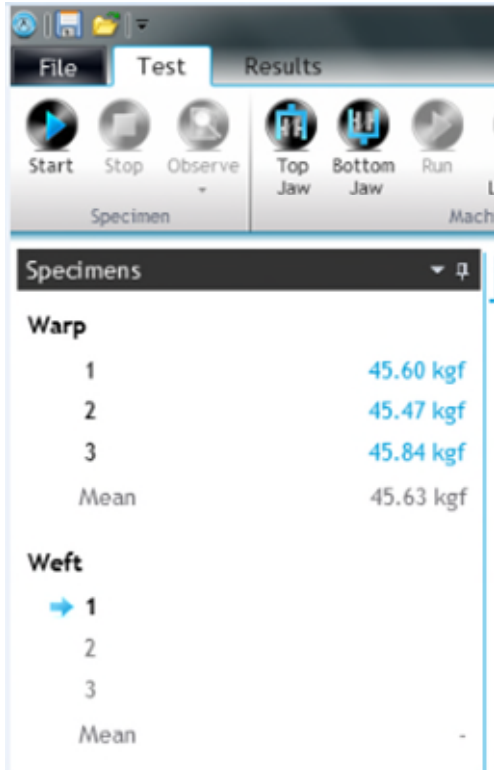

Any test results associated with specimens 4 and 5 would be lost.

Click Start to continue testing.



Adding a Specimen

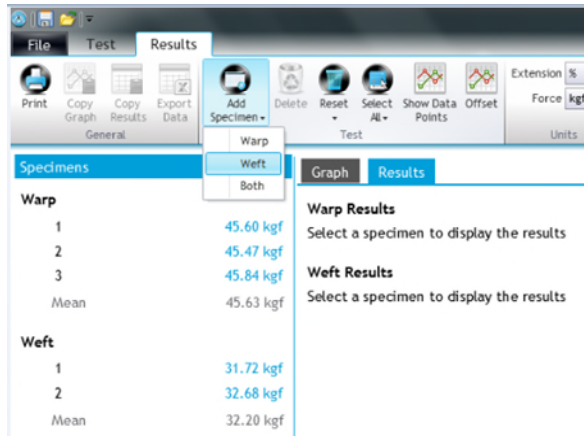

To add a specimen, click the Add Specimen button. You can add specimens to just one direction or both directions.

In this case, we are showing specimens being added to the weft direction.

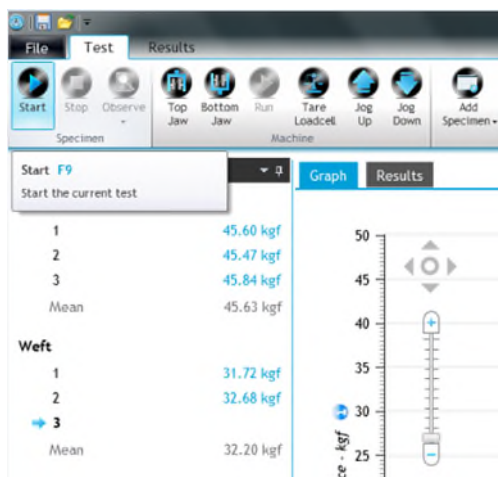

An additional specimen has been added to the weft direction.

Click Start to continue testing.

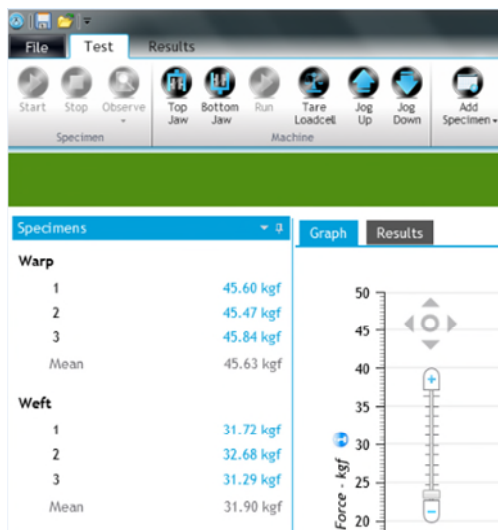

Delete a Specimen

To delete a specimen, first select the specimen or specimens and then click the Delete button.

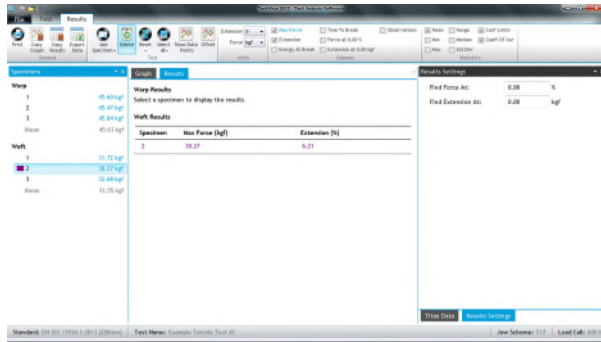

You will be prompted with a message asking for confirmation. The default response is No, do not delete. To delete, click Yes.

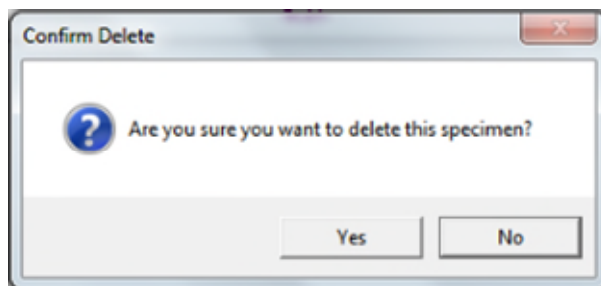
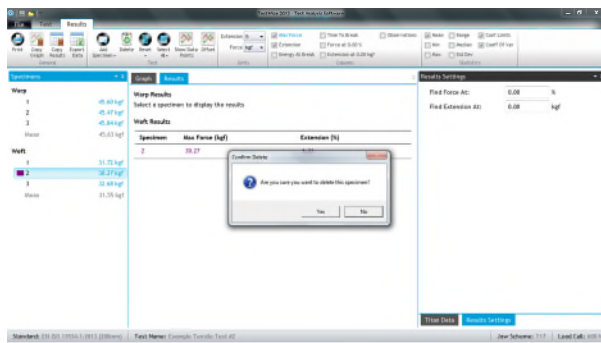

Note: once the specimen is deleted it cannot be restored.

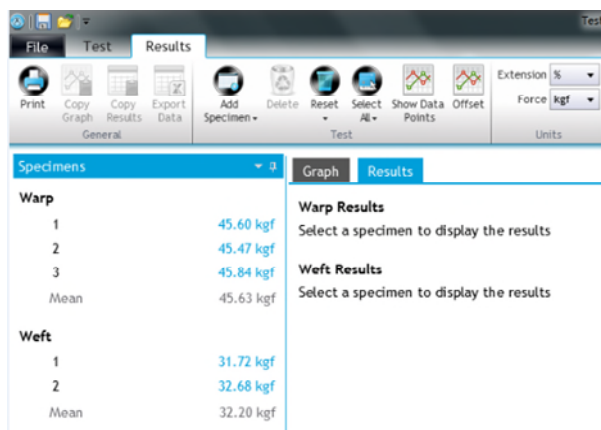

The final results.

USEFUL FEATURES

Selecting Jaw Schemes

Selecting the correct Jaw Scheme is an important part of the test procedure.

The user must advise TestWise which jaws or other tooling is connected to Titan in order to ensure the correct jaw separation (gauge length) is obtained.

If there is a mismatch then the consequences could range from incorrect jaw separation to damage to the attached tooling and load cell !

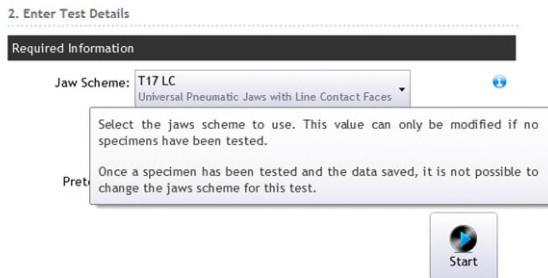

In this example we are setting up to carry out a tensile test according to ISO 13934-1.

TestWise always shows the last Jaw Scheme to be used.

So, in this case, T17 jaws with Line Contact jaw faces would not be the correct choice.

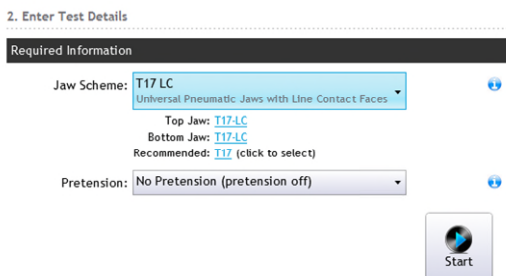

When selected, some standards (but not all), will prompt the user with a Recommended Jaw Scheme.

In this example, T17 is recommended.

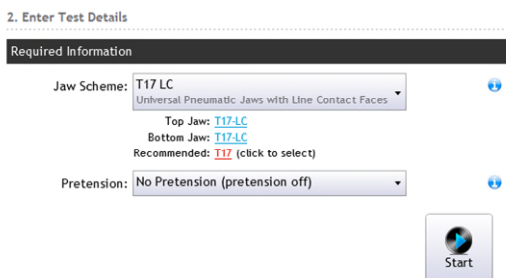

Point to the recommended Jaw Scheme and the test will switch from T17 to T17.

Click T17 and the Recommended Jaw Scheme will be selected.

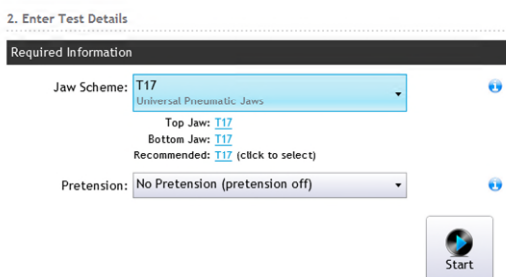

The Recommended Jaw Scheme, T17, is now selected.

2. Enter Test Details

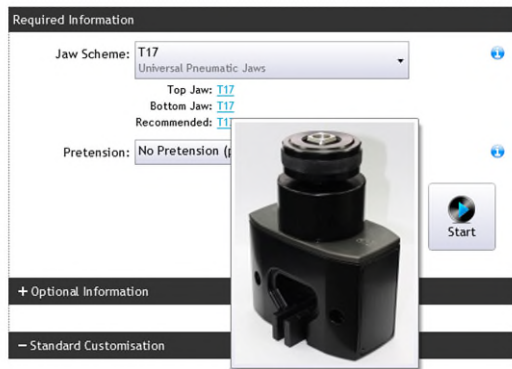

If the mouse is hovered over Top Jaw: [T17](#) then an image of the jaw is displayed for 5 seconds.

2. Enter Test Details

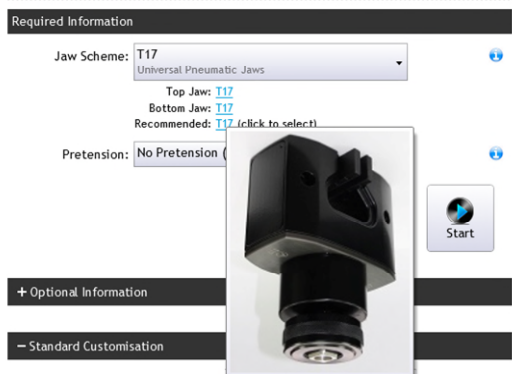

If the mouse is hovered over Bottom Jaw: [T17](#) then an image of the jaw is displayed for 5 seconds.

Show Data Points

Sometimes it is desirable to know the force and extension values of an exact point on the graph. Look at the screenshot below, we want to know the exact force and extension values at the point indicated by the red arrow.

Click **Show Data Points** on the TestWise ribbon.

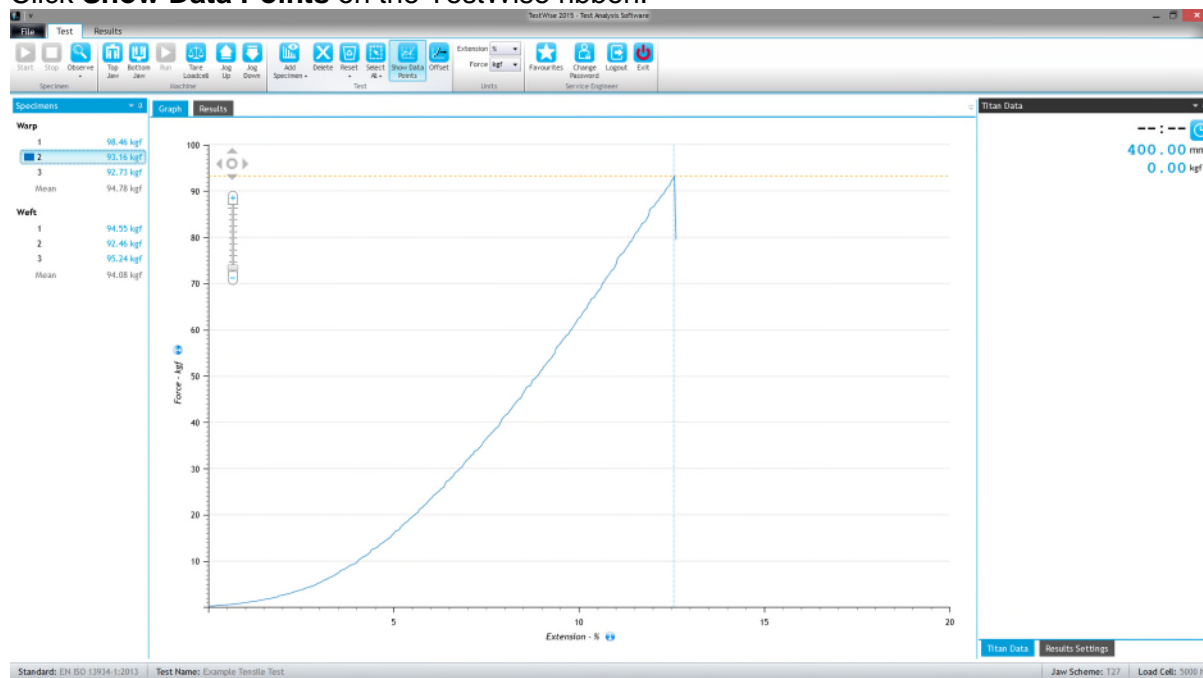

Using the mouse, point the precise location on the graph and a popup will be displayed with the required information.

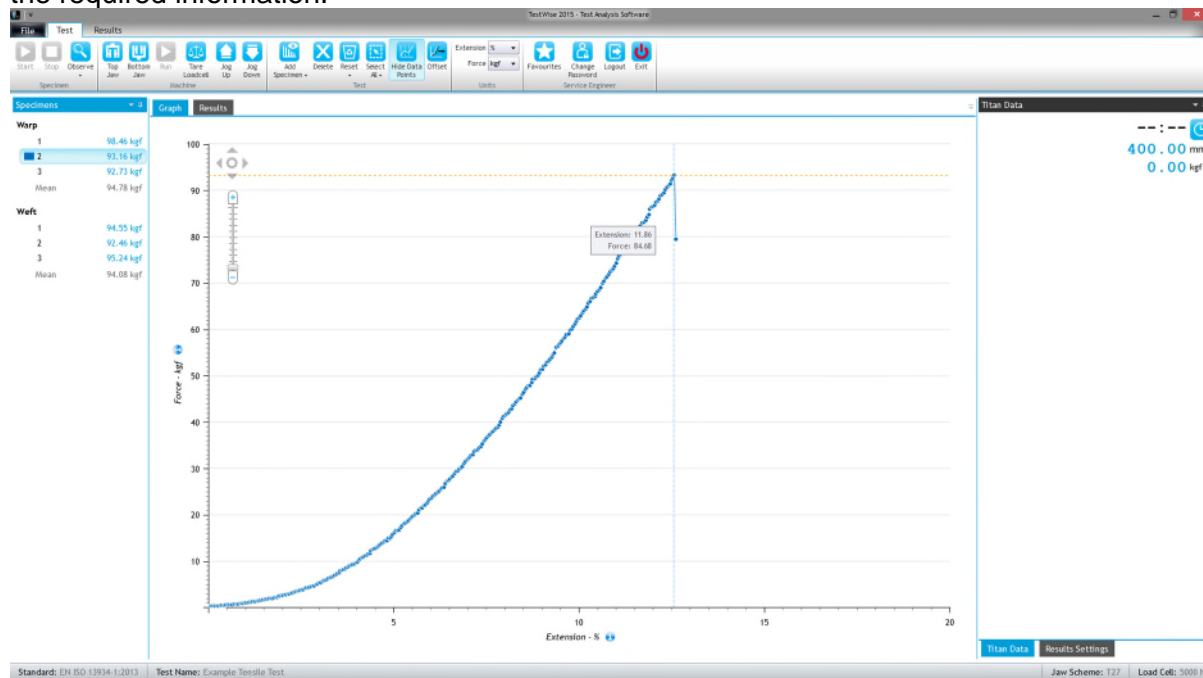

To switch back to a normal graph, click **Hide Data Points**.

Find Force or Find Extension

Find Force at a specified extension and/or Find Extension at a specified force are often requested in buyer's specifications. For this reason we include this feature in many tensile standards.

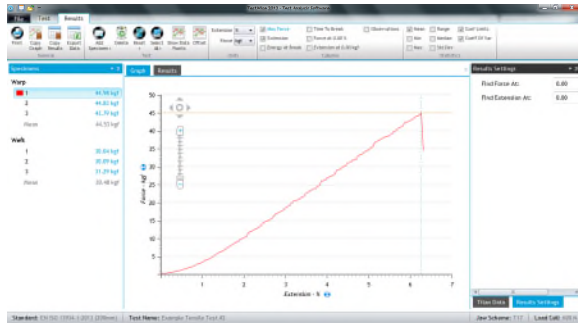

Select the specimen or specimens.

If it is not already selected, click Results Settings.

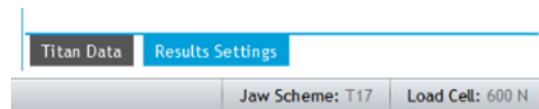

Results Settings

Find Force At: %

Find Extension At: kgf

Extension at which to find force.

Force at which to find extension.

Max Force
 Time To Break
 Observations
 Extension
 Force at 5.00 %
 Energy At Break
 Extension at 20.00 kgf
 Columns

The values will be reflected in the Ribbon.

Check the required results.

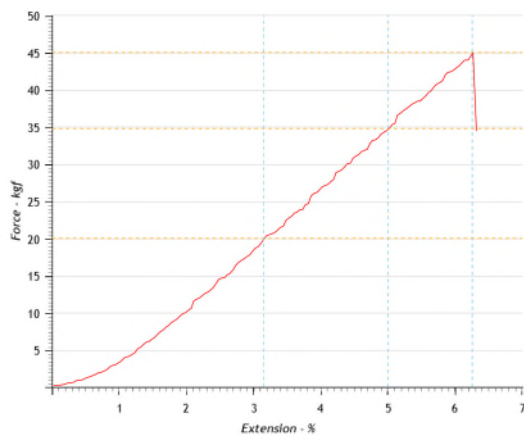

If a single specimen is selected the graph will show the specific overlays.

This graph was copied using the Copy Graph feature which copies the graph as it is currently displayed.

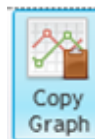

Continued in next section.

Auto Hide Panes

The results for All Specimens would be displayed like this:

The screenshot shows the TestWise 2013 - Test Analysis Software interface. The main window displays results for Warp and Weft specimens. The Warp Results table is as follows:

Specimen	Max Force (kgf)	Extension (%)	Force at 5.00 % (kgf)	Extension at 20.00 kgf (%)
1	44.98	6.25	34.75	3.15
2	44.83	6.30	35.57	3.18
3	43.79	6.17	34.85	3.17
Mean	44.53	6.24	35.06	3.17
Conf Limits	±1.61	±0.17	±1.11	±0.04
Coeff Of Var	1.45%	1.12%	1.28%	0.53%

The Weft Results table is as follows:

Specimen	Max Force (kgf)	Extension (%)	Force at 5.00 % (kgf)	Extension at 20.00 kgf (%)
1	30.04	6.26	23.90	4.32
2	30.09	5.84	25.05	4.16
3	31.29	6.29	24.71	4.19
Mean	30.48	6.13	24.55	4.22
Conf Limits	±1.76	±0.63	±1.46	±0.21
Coeff Of Var	2.32%	4.12%	2.39%	2.00%

The interface also shows a Specimens pane on the left with Warp and Weft data, and a Results Settings pane on the right. The status bar at the bottom indicates Standard: EN ISO 13934-1:2013 (200mm), Test Name: Example Tensile Test #2, Jaw Scheme: T17, and Load Cell: 600 N.

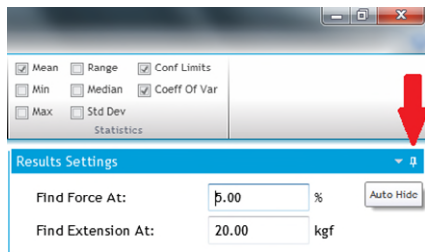

The Titan Data / Results Settings panes can be hidden (as shown above) by clicking the Auto Hide pin.

The Specimens pane can also be hidden in the same way.

This is useful if you are displaying a large number of results columns and the display becomes congested.

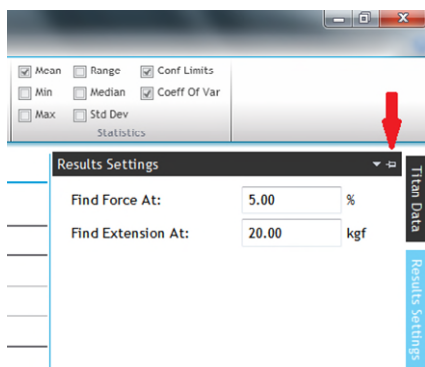

To restore the panes click the Auto Hide pin again.

Copy Graphs, Copy Results and Export Data

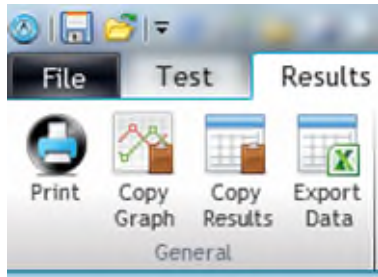

You can find these features in the General section of the Results ribbon.

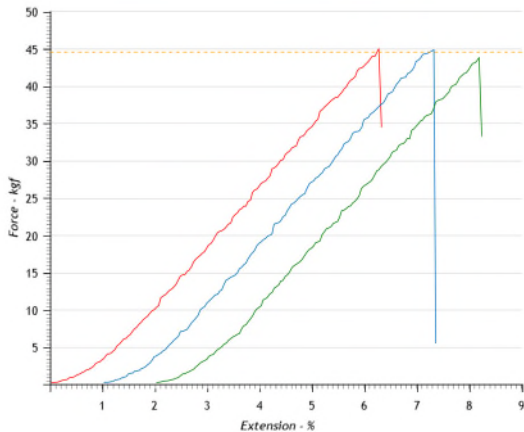

Copy Graph and Copy Results will copy the Graph or Results as they are currently displayed. They are copied to the Clipboard ready for pasting into other application.

Warp Results

Specimen	Max Force (kgf)	Extension (%)	Force at 5.00 % (kgf)	Extension at 20.00 kgf (%)
1	44.98	6.25	34.75	3.15
2	44.83	6.30	35.57	3.18
3	43.79	6.17	34.85	3.17
Mean	44.53	6.24	35.06	3.17
Conf Limits	±1.61	±0.17	±1.11	±0.04
Coeff Of Var	1.45%	1.12%	1.28%	0.53%

	A	B	C	D
1	0.008725	0.250206	0.009038	0.236624
2	0.057333	0.261625	0.057035	0.287539
3	0.095659	0.269786	0.09537	0.29637
4	0.13305	0.310865	0.133394	0.329989
5	0.183529	0.427099	0.18326	0.404291
6	0.220608	0.545236	0.22066	0.561924
7	0.257999	0.589574	0.258372	0.632191
8	0.308478	0.653217	0.308551	0.688846
9	0.345557	0.872515	0.345639	0.841865
10	0.382948	0.921892	0.383351	0.956911
11	0.433115	0.975867	0.433217	1.032157
12	0.470506	1.145894	0.470618	1.358401

Export Data exports the raw extension and force values for each specimen to a comma separated value (CSV) file which can be opened in Microsoft Excel.

There are no column headings.



Reset

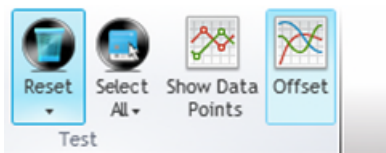

Reset
Reset the selected specimens or the entire test. This will delete all data, results and recorded observations.

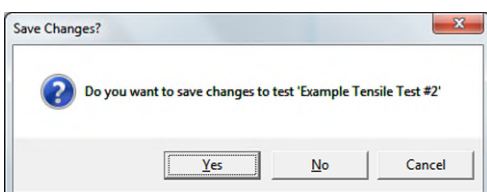
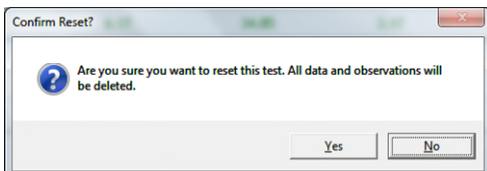
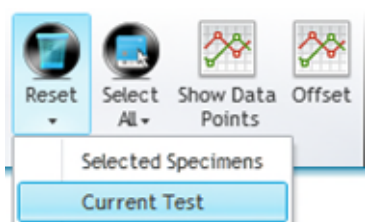
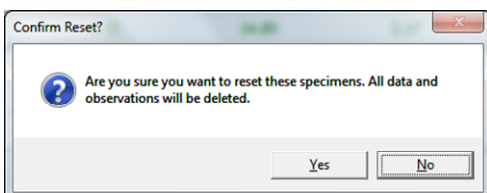
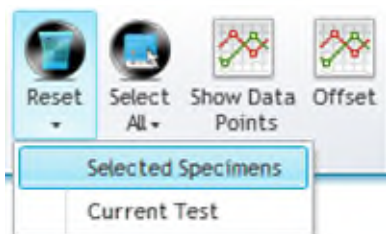
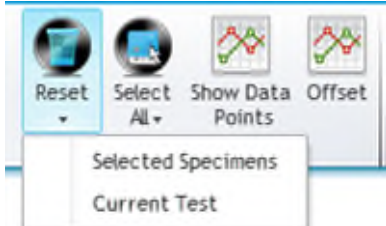

Reset is a time saving feature which can be accessed from the Test and Results tabs.

Reset the selected specimens or the entire test. This will delete all data, results and recorded observations.

There are two Reset options, both of which should be used with caution.

Before using Reset ensure you save any important results.

This option is like deleting specimens.

After saving your test results, to carry out another test with the same standard and settings then select Reset Current Test.

Answer "Yes", the default response is "No".

Ensure you save changes to your previous test.

Manual Control

This option is used to manipulate Titan outside of a normal testing routine. It is not designed for performing tests.

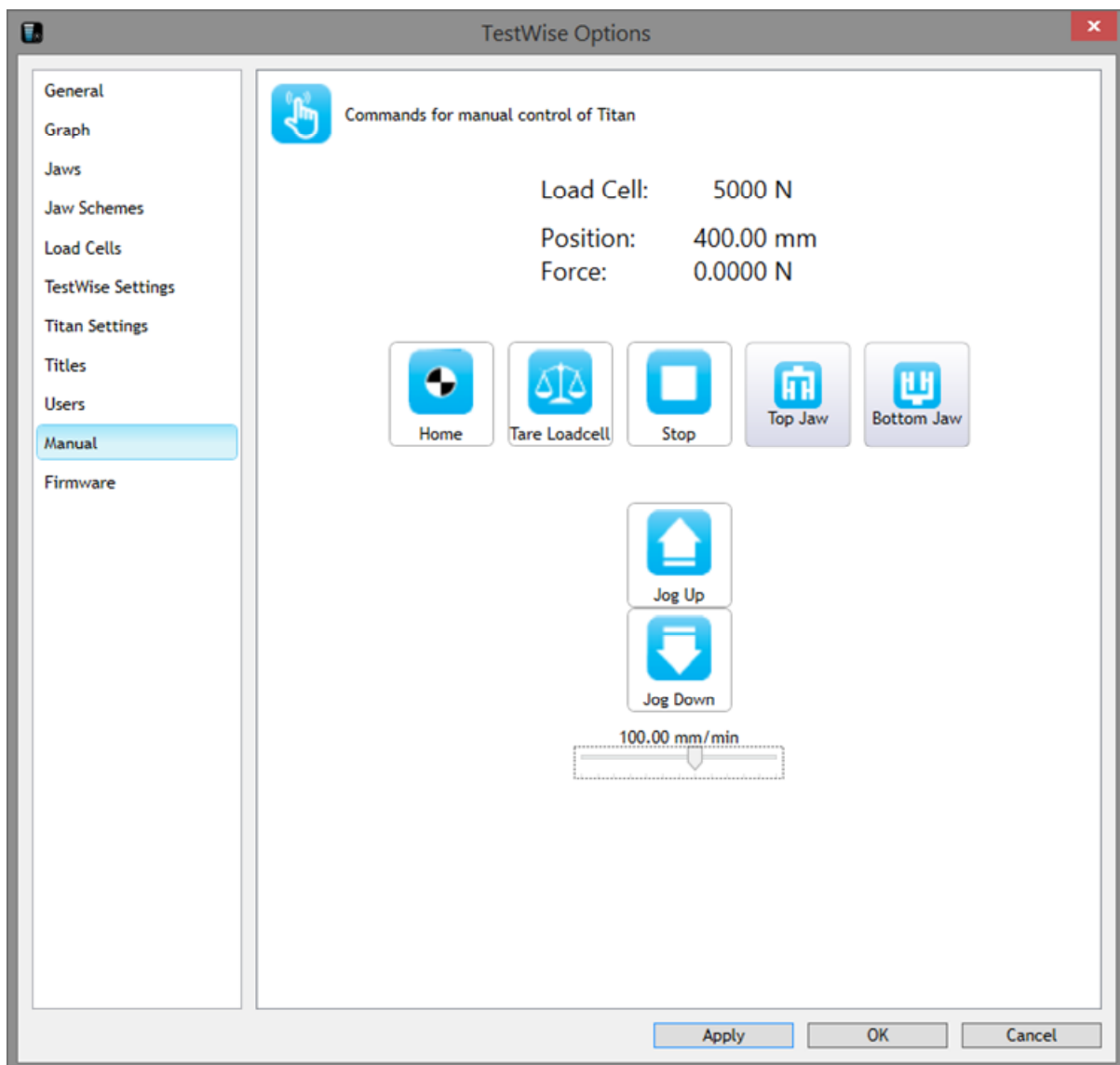

Load Cell: 5000 N
Position: 400.00 mm
Force: 0.0000 N

Live Data showing the currently connected loadcell, current position and current force are displayed.



Sends the carriage to the top of the column, the Home Position.



Tares the loadcell reading, resets the force to zero.



Stops the carriage if it is moving.



Used to open or close the jaws.



Used to move the carriage up or down and various speeds set by the slider.



The 4 arrow keys on the keyboard can also be used.



Collapse and Expand

Some sections of the display can be expand or collapsed to create more space on screen. This example shows the Enter Test Details sections when preparing for a new test.

- Optional Information

Batch Nbr:

Customer:

Quality:

Shade:

Comments:

This section can be collapsed by clicking anywhere on the bar.

+ Optional Information

+ Standard Customisation

Standard Customisation can be expanded by clicking anywhere on the bar.

- Standard Customisation

Number of Specimens: ⓘ

Directions: ⓘ

Break Detection: % ⓘ

To reverse expand or collapse, click the bar again.

USING THE STANDARDS EDITOR

Creating Custom Standards

You can create a Custom standard (or “user-defined standard”) by copying a Built In standard. Built In Standards are those which are supplied by James Heal and installed with **TestWise**. You can Copy Built In Standards but you cannot edit them. Once a Custom Standard is created, you can edit or copy it.

Creating a Custom Standard is useful for creating both simple and complex standards. The system relies on editing a pre-existing Standard, therefore, Standards cannot be created from a blank template. This means you must choose a Standard which most resembles what you want to do and then use this as your template. In cases where this is not possible, please contact James Heal for help and advice.

In the following example we are going to create a new tensile test.

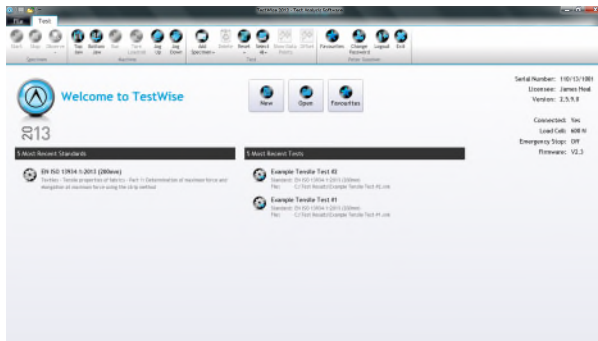

Start **TestWise** and login with Administrator privileges.

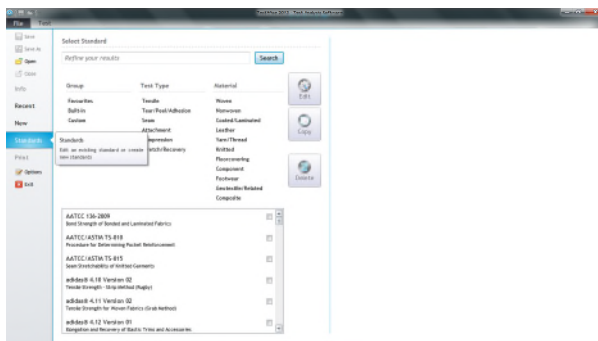

From the File menu, select Standards.

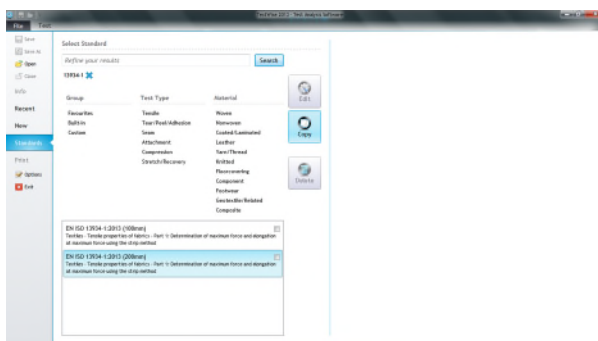

Find the Standard to use as a template.

Select the Standard from the list and click Copy.

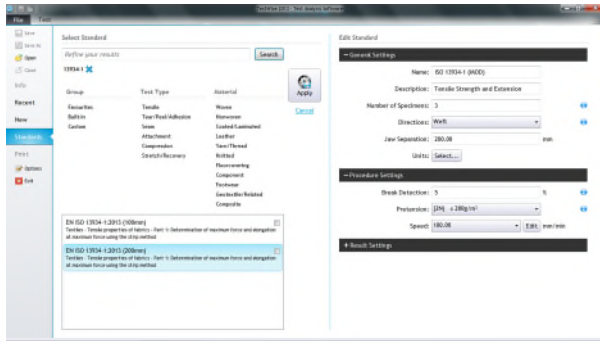

The parameter settings for the selected Standard are displayed.

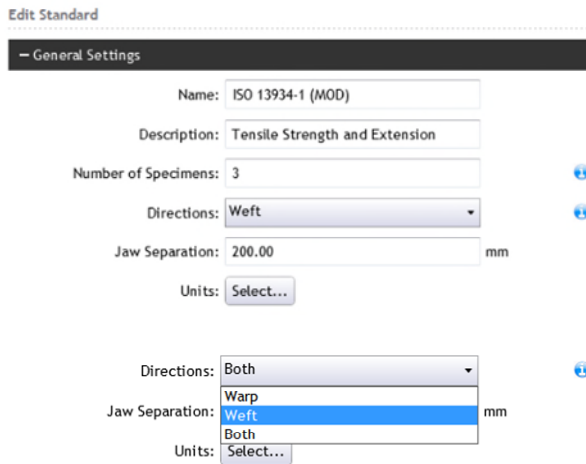

Type in a Name and Description for the new Standard. We have also reduced the number of specimens from 5 to 3, testing weft only specimens.

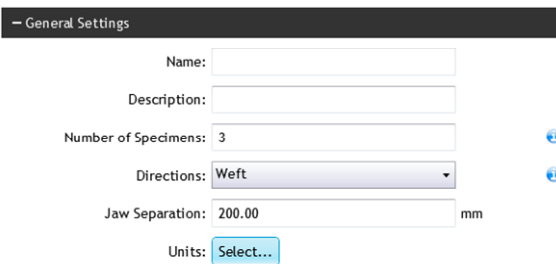

We only want to test specimens in the weft direction.

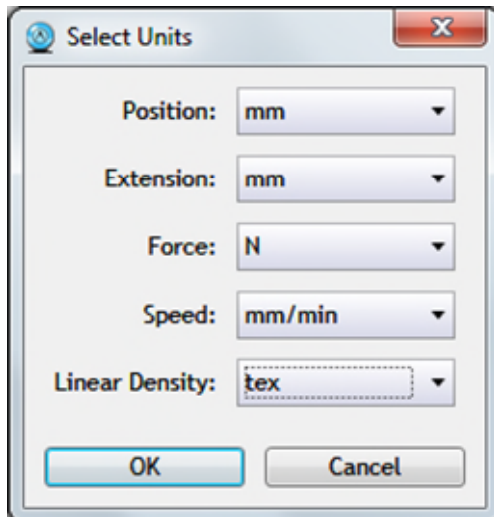

To change the units used in the standard, click Units: Select.

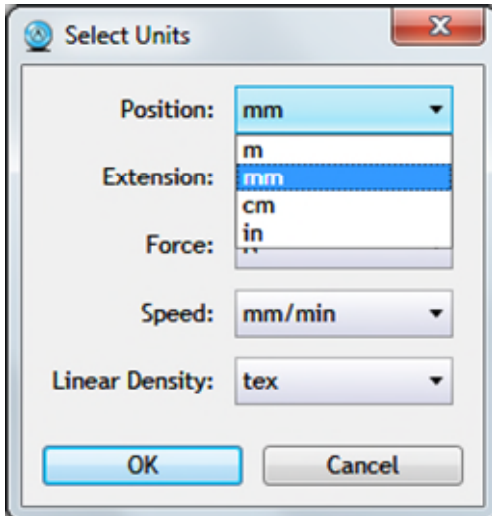

Position units.

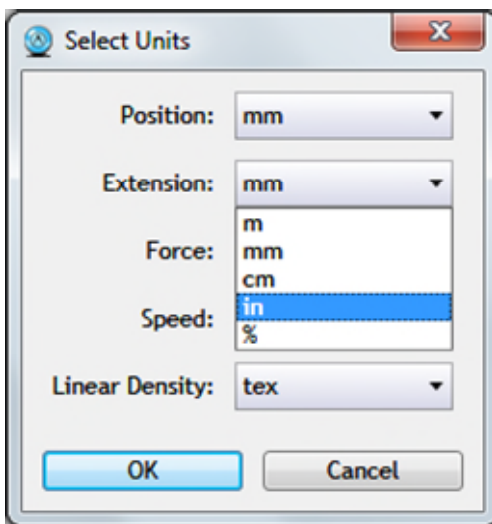

Extension units.
Note “%” is also available.

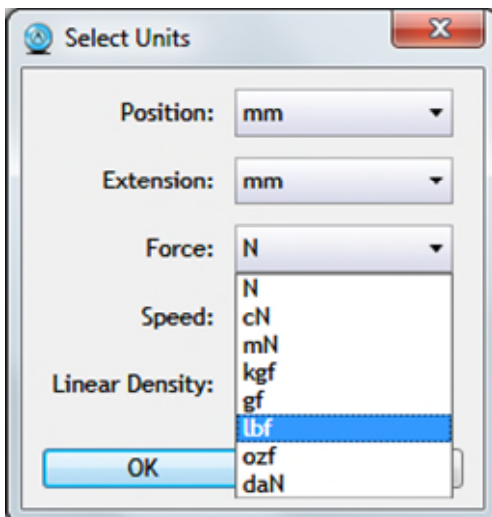

Force units.

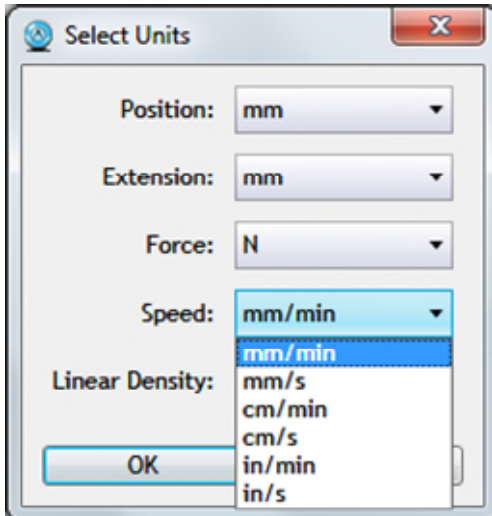

Speed units.

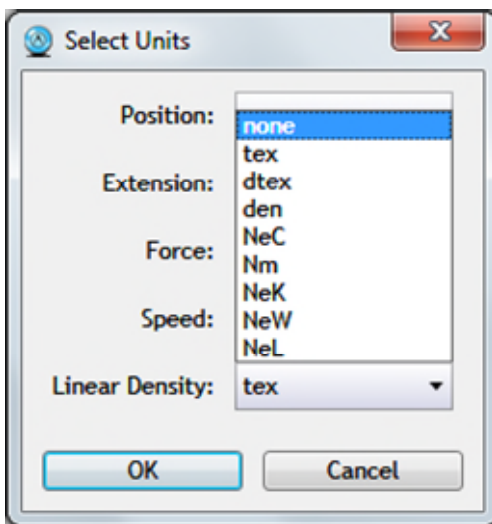

Linear Density is only used in Yarn Tensile Strength tests. If a linear density is specified the results are expressed as tenacity. If no linear density is specified, the results are expressed directly as force.

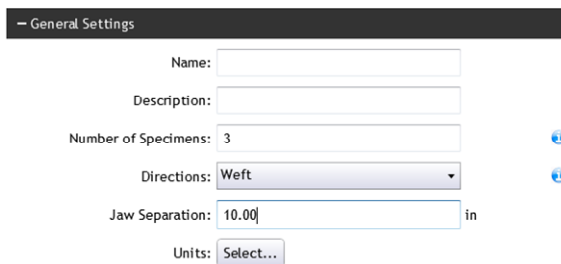

Enter a Jaw Separation (also known as Gauge Length or Gage Length). In this example we are setting a value of 10 inches.

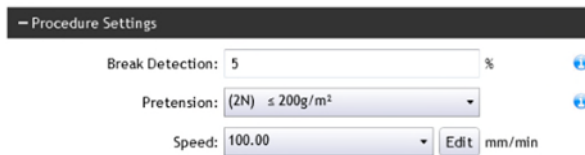

If required, change the:
break detection setting
default pretension setting
speed

Pretension: (2N) $\leq 200\text{g/m}^2$

- No Pretension (pretension off)
- (0.5N) Fabrics with stretch
- (2N) $\leq 200\text{g/m}^2$
- (5N) $> 200\text{g/m}^2$ to 500g/m^2
- (10N) $> 500\text{g/m}^2$

Speed: 100.00 mm/min

- 20.00
- 100.00

If the fabric has an extension at break of less than 8% then change the speed to 20 mm/min.

Edit Options

Units: N

1: 20.00 Delete

2: 100.00 Delete

New

OK Cancel

Alternatively, different speed values can be specified by clicking Edit which displays this dialogue box.

Edit Options

Units: N

1: 50.00 Delete

2: 100.00 Delete

3: 300.00 Delete

New

OK Cancel

You can change the existing speed options or add a New option.

Edit Options

Units: N

1: 100.00 Delete

2: 300.00 Delete

New

OK Cancel

Pressing Delete will remove the specified option.

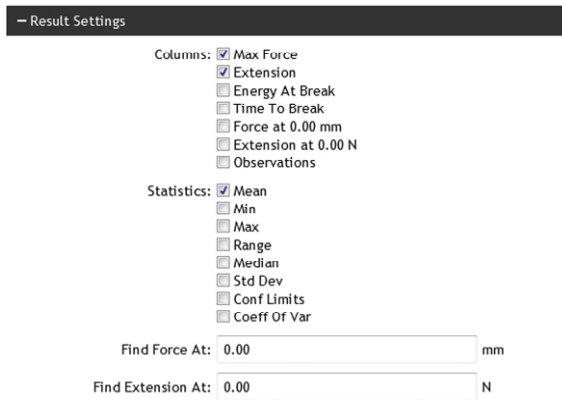

Change which Results and Statistical values are selected and displayed.

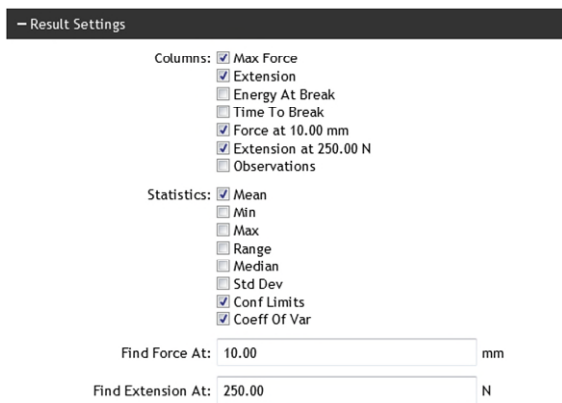

Selected Find Force and Find Extension.

Selected Confidence Limits and Coefficient of Variation.

Specified default Find Force and Find Extension values. These can be changed at test time.

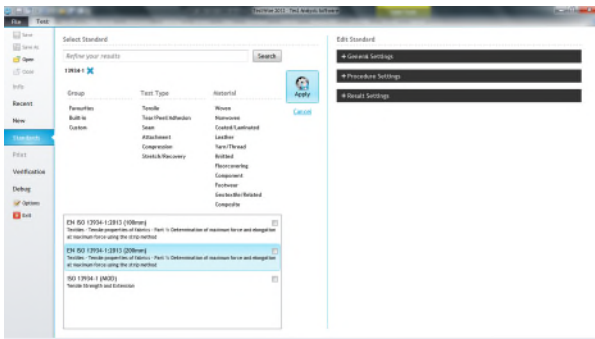

Click Apply to save the new Standard.

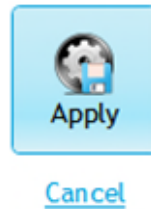

Your new standard is now available in the Standards Library ready to make a new test as normal.

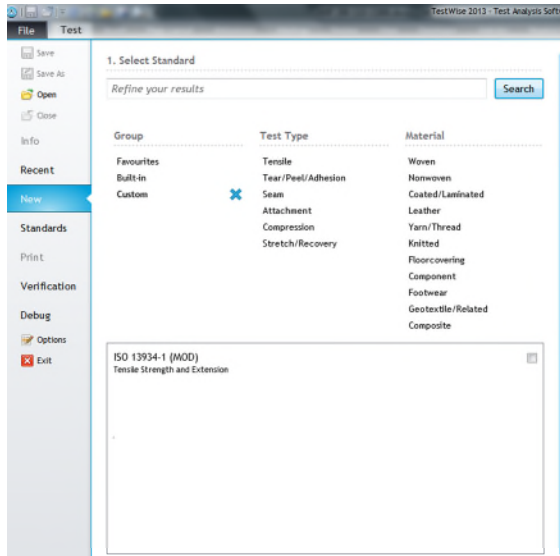

Custom standards can be found quickly by clicking the Custom Group.

SETTING UP A NEW JAW SCHEME

Any Jaws which are purchased at the same as the **Titan** instrument will be configured ready for use. However, Jaws purchased subsequently need to be setup manually using the following instructions. In addition you may wish to set up unusual combinations of Jaws to provide the best gripping and holding options for the specimen under test.

In this example we will pair T18 and T17 Jaws.

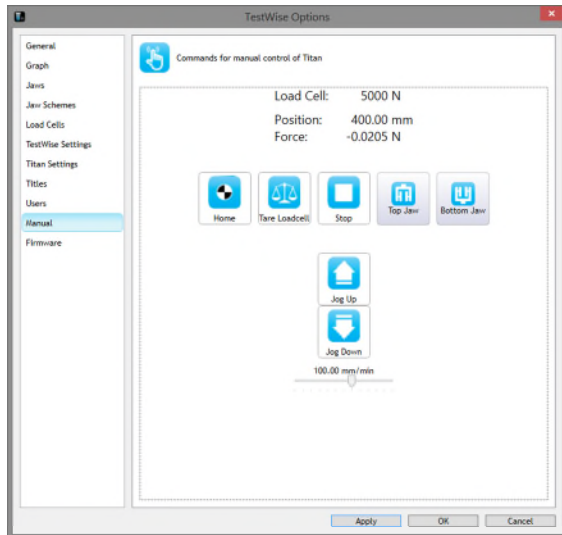

First, provide enough space between the top and bottom Jaw connection to be able to fit the new Jaws.

From TestWise
File > Options > Manual

If the instrument has not been “Homed” since switch on then click the Home button.



Then use the Jog Up and Jog Down buttons to move the top and bottom Jaw connections to a suitable position for fitting the new Jaws.

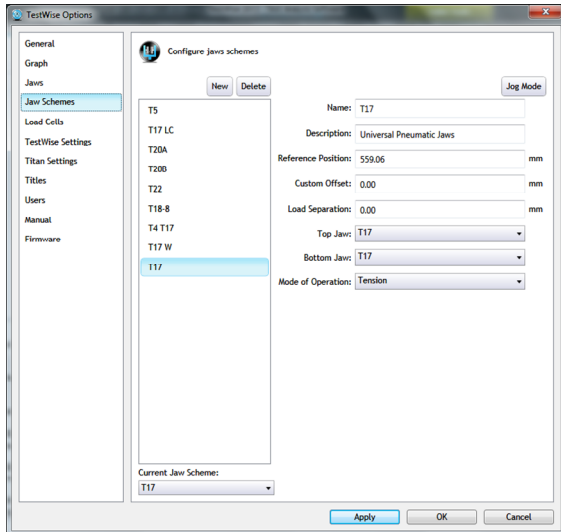

Move to Jaw Schemes in TestWise Options.

The list shown here are the Jaw Schemes currently set up:

- T5
- T17 LC
- T20A
- T20B
- T22
- T18-8
- T4 T17
- T17 W
- T17

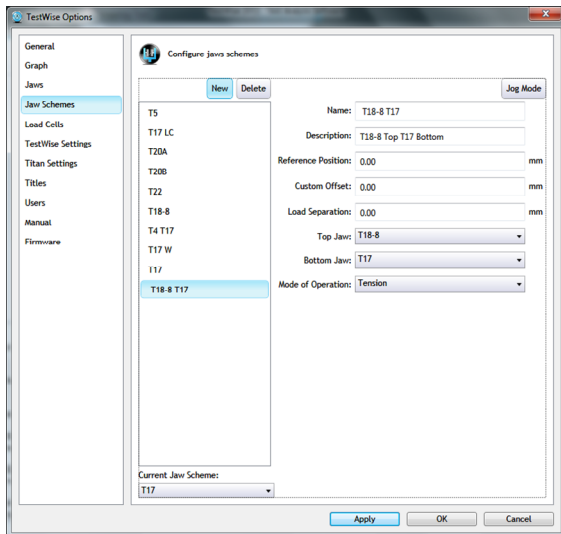

To begin the process of creating a new Jaw Scheme, click the New button.

Enter the details required.

Enter a Name and Description for the Jaw Scheme.

Reference Position, Custom Offset and Load Separation will be covered later.

Select the Top Jaw and Bottom Jaw from the drop-down lists.

Select the Mode of Operation: Tension or Compression:
 This selection dictates the direction of movement of the carriage.
 Selecting Tension results in the Carriage moving up, selecting Compression results in the Carriage moving down.

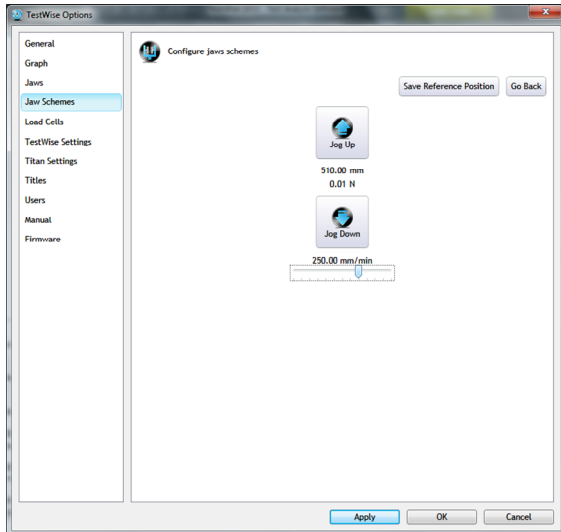

To set the Reference Position, select Jog Mode.

The Reference Position is the point at which the top and bottom Jaws just touch without producing any force on the Load Cell.

Using the Slider, set a suitable speed, e.g., 100 mm/min.



Custom Offset

Some Jaw Schemes require a Custom Offset because the “nip” points cannot be brought together.

In this case the Custom Offset is 17.5mm.

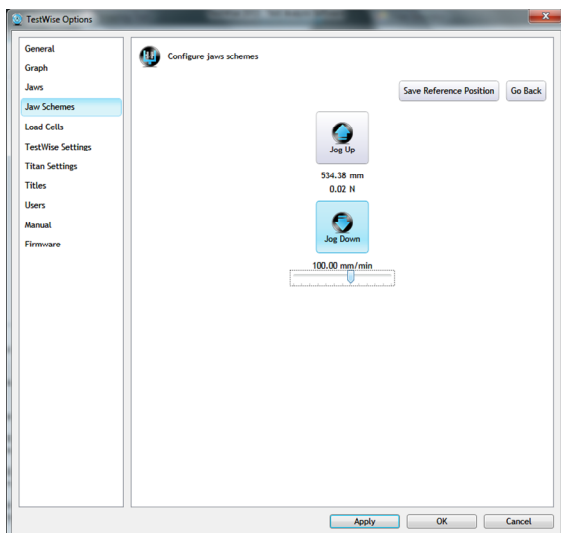
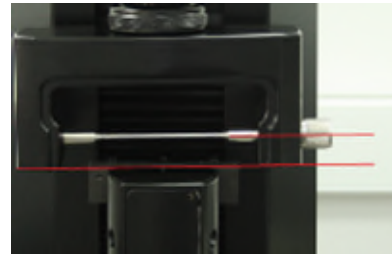

Use the Jog Up and Jog Down buttons to move the Top Jaw carefully downwards until it just touches the Bottom Jaw without producing any force on the Load Cell.

As the Top and Bottom Jaws come in close proximity you can reduce the speed.

Once the Jaws are touching, click the Save Reference Position button, then the Go Back button.

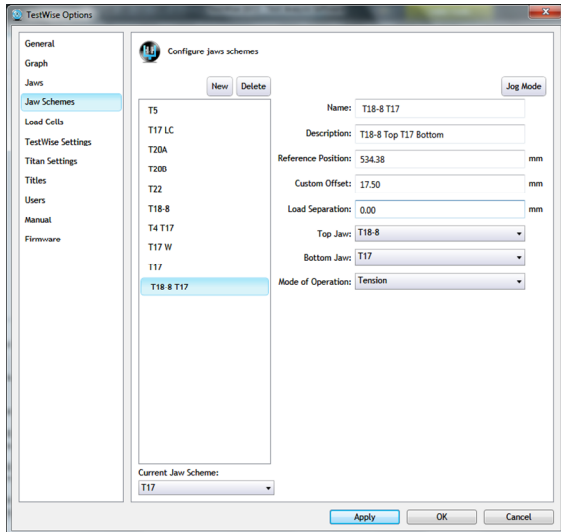

You can see that the Reference Position has been saved (534.38 mm).

To finish, click Apply and OK.

The “T18 T17” Jaw Scheme has now been created and set up.

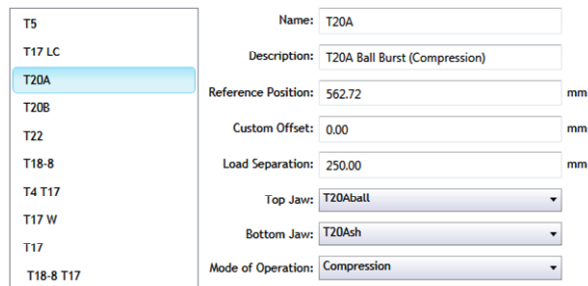

Load Separation is used mostly in compression tests when the tooling may be dangerous or prevents loading a new specimen.

When the test has completed, the carriage will move up, 250 mm in this case, providing good and safe access to the specimen holder.

USING THE NEW JAW SCHEME



Place the specimen on the bar.

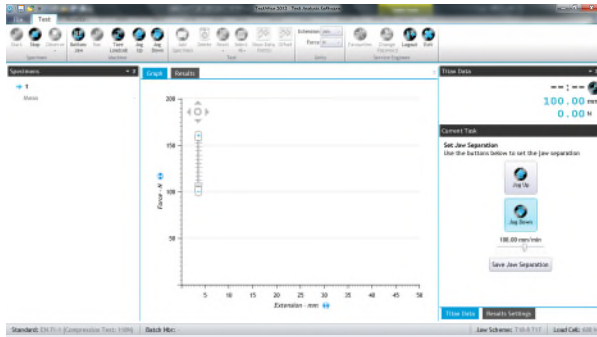

Using the Jog Down button (or Jog Up button if required), move the Top Jaw until the specimen can be gripped by the Bottom Jaw.



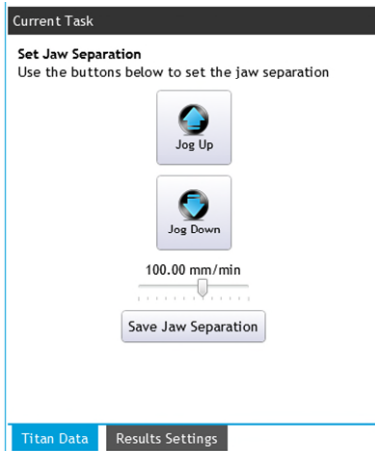

When the position is suitable, click the Save Jaw Separation button.

Save Jaw Separation

This Jaw Separation will now be used during the test.

Note: the Jaw Separation can only be set manually for the first specimen.

Continue testing as usual.

T19 CHECK WEIGHT SET

The **T19 Check Weight Set** should be used periodically, between annual loadcell calibrations, to determine the force reading accuracy and consistency of the Titan Universal Strength Tester.

The 794-891 - T19 Check Weight Set cannot be used on Titan¹, Titan² or Titan³. If you require a Check Weight Set for these models then contact your James Heal Agent and ask for 794-817.

Instructions for Use

Power on the Titan instrument and start the TestWise software and Login as normal.

Allow the instrument 30 minutes to “warm up” so that the loadcell and its associated electronics stabilise at room temperature. This is good practise in general whenever you are using Titan and is always done prior to this verification procedure.



Remove both the top and bottom jaws from the screw thread adaptor.

Fit the Check Weight Holder in place of the top jaw. This allows the five circular weights to be centrally positioned on the loadcell.

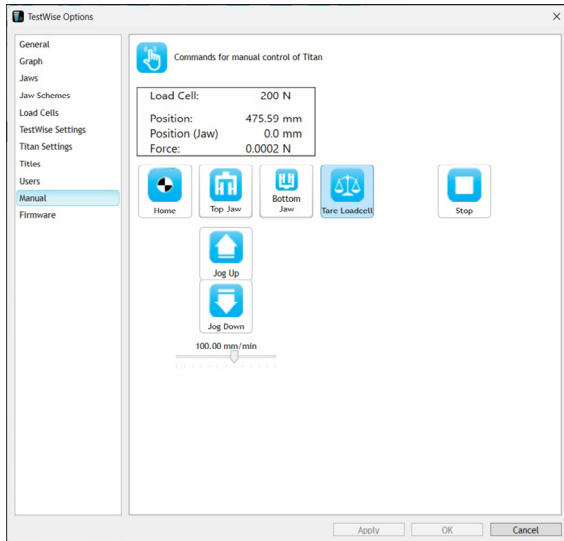

From the File menu, choose Options, then Manual.

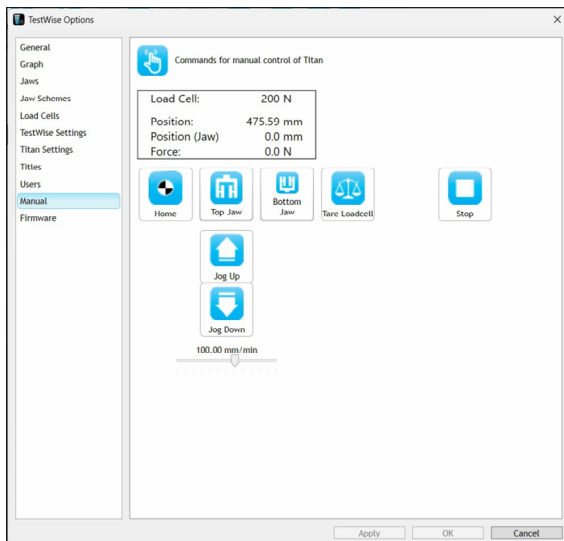
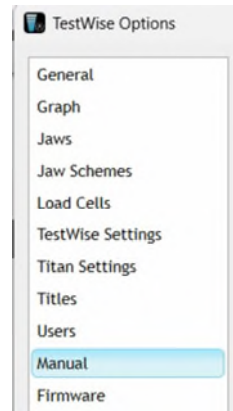

Click Tare Loadcell to zero the loadcell reading.



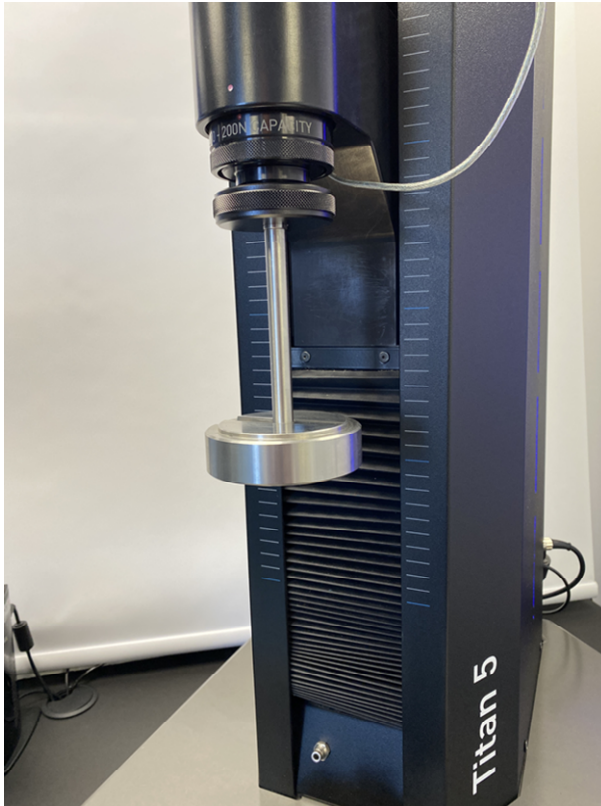

One at a time, carefully place all 5 circular check weights on to the Check Weight Holder, ensuring they are mounted centrally.

Record the Force reading after the fifth (final / last) weight has been added.

Load Cell:	200 N
Position:	475.59 mm
Position (Jaw)	0.0 mm
Force:	9.996 N

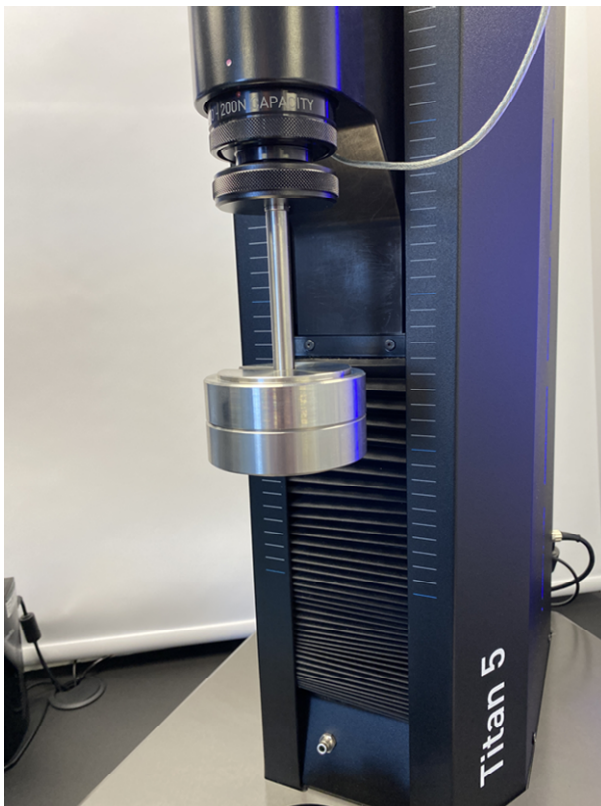

The second weight.

Load Cell:	200 N
Position:	475.59 mm
Position (Jaw)	0.0 mm
Force:	19.992 N

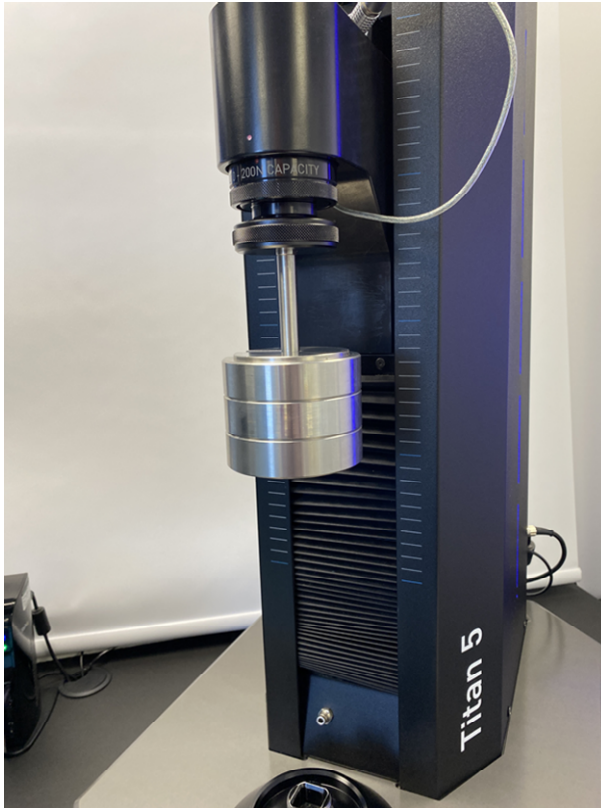

The third weight.

Load Cell:	200 N
Position:	475.59 mm
Position (Jaw)	0.0 mm
Force:	30.005 N

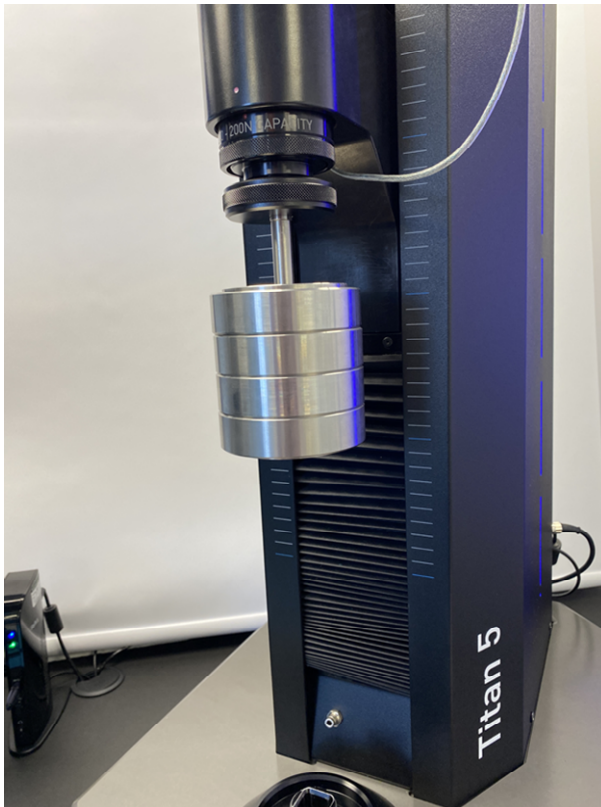

The fourth weight.

Load Cell:	200 N
Position:	475.59 mm
Position (Jaw)	0.0 mm
Force:	40.003 N

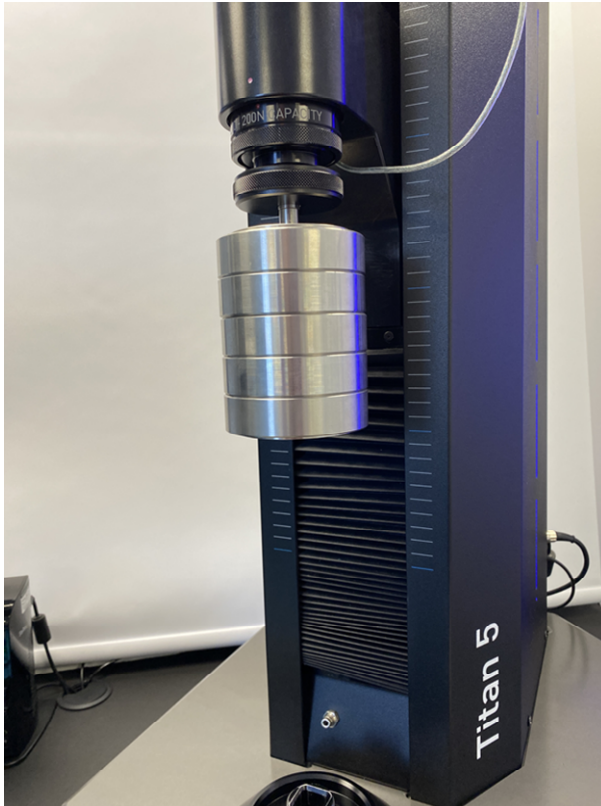

The fifth and final weight.

Load Cell:	200 N
Position:	475.59 mm
Position (Jaw)	0.0 mm
Force:	50.002 N

The total force you have added is 50N. The force reading on the screen should confirm this. You can use this value to determine the accuracy and consistency of the loadcell fitted to the Titan. For 0.5% this value should be between 49.75 N and 50.25 N (see notes on next page).

In your log you should record:

- Date and time
- Load cell capacity and serial number
- The final reading from all 5 weights
- Pass / fail according to the tolerances above
- Initials of the operators carrying out the check

If the reading is out of tolerance and the loadcell fails the check, please repeat the check to ensure no errors have been made in the procedure. If the loadcell still fails the check, please contact your James Heal Agent to arrange for recalibration of the load cell(s).

Notes Relating to Gravitational Field Strength and T19 Check Weights

The acceleration due to gravity on Earth is not a uniform 9.81 m/s^2 universally; it ranges from approximately 9.76 to 9.83 m/s^2 based on location. These variations of approximately 0.7% from place to place are primarily caused by the Earth's non-spherical shape (equatorial bulge), centrifugal force from rotation, altitude, and local geology.

The exact standard value defined for scientific and metrological purposes is 9.80665 m/s^2 . This value represents the average acceleration that any object experiences near Earth's surface due to the planet's mass and size.

Generally, the closer to the poles you are located, you are closer to the centre of Earth's mass, resulting in higher gravity. If you are closer to the equator, you are further from the centre, resulting in weaker gravity.

For example, Sri Lanka located in the Indian Ocean, an area featuring the one of the lowest gravity values. This anomaly means the gravitational pull is weaker in this region. The gravitational field strength in Colombo is 9.7811 m/s^2

Gravity's main implication in metrology is for weight measurements in that weight is a variable force ($W = m \times g$) rather than a constant amount of matter (mass). While mass remains constant everywhere, weight changes depending on local gravitational field strength, meaning objects weigh less at higher altitudes and slightly less on the equator than at the poles.

Using Sri Lanka again as example, the force range for acceptance on the previous page (i.e., 49.75 N and 50.25 N in the UK) would be adjusted to 49.62 N and 50.12 N in Sri Lanka.

APPLICATIONS

This section of the Operator's is to provide an insight into Testing on Titan. It is by no means an exhaustive compilation of examples but hopes to give users and operators an understanding of the use of Titan and TestWise along with the specific tooling used in the examples.

It is import when carrying out any tests to consult an up-to-date copy of the relevant standard. The actual standard contains a wealth of detail which it is not possible to cover in this Operator's Guide and furthermore standards are constantly being revised and updated.

The applications covered in this section are based on textiles and leather, and the majority of textile tests are designed for the testing of fabrics, either woven, knitted or nonwoven.

Tensile Strength and Elongation

A wide variety of techniques have been developed to measure tensile strength and elongation. Two very popular methods are described below. Strength tests for yarn are covered separately later in this section.

Fabric – strip test

This example is based on ISO 13934-1.

The specimen is approximately 300mm in length and threaded down to a width of 50mm.

If the fabric cannot be threaded down then it can be carefully cut to 50mm.

The gauge length, or initial jaw separation is typically 200mm.

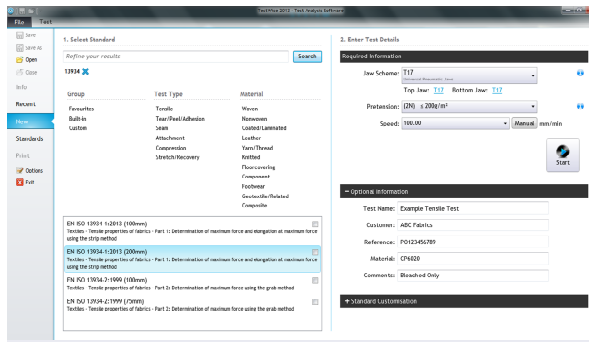

Search for **13934** and select the correct option. Select the correct Jaw Scheme, in this case T17.

Set the Pretension value based on the fabric weight.

Speed defaults to 100 mm/min but there is an option of 20 mm/min which is used for fabrics which show very little elongation.

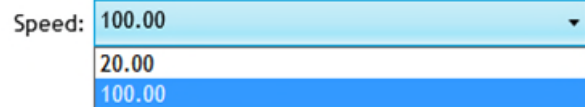

Enter sample details.

Change number of specimens and test directions if required.

Click **Start**.

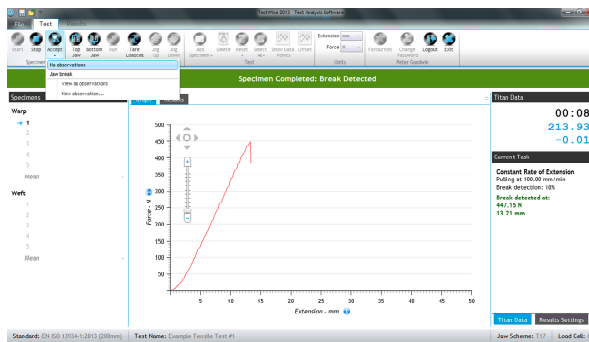

Place the specimen centrally in the jaws.

When the specimen breaks the force and extension at break are shown in green.

Press **Accept**.

When the results are accepted, the breaking force is displayed on the left against the specimen number.

Continue with the remaining specimens.

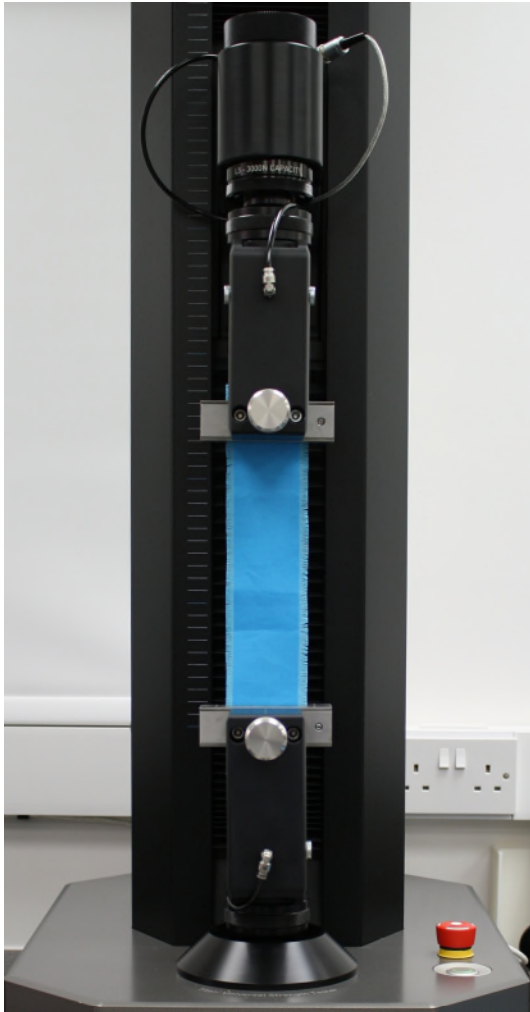

Specimen in the jaws ready for testing

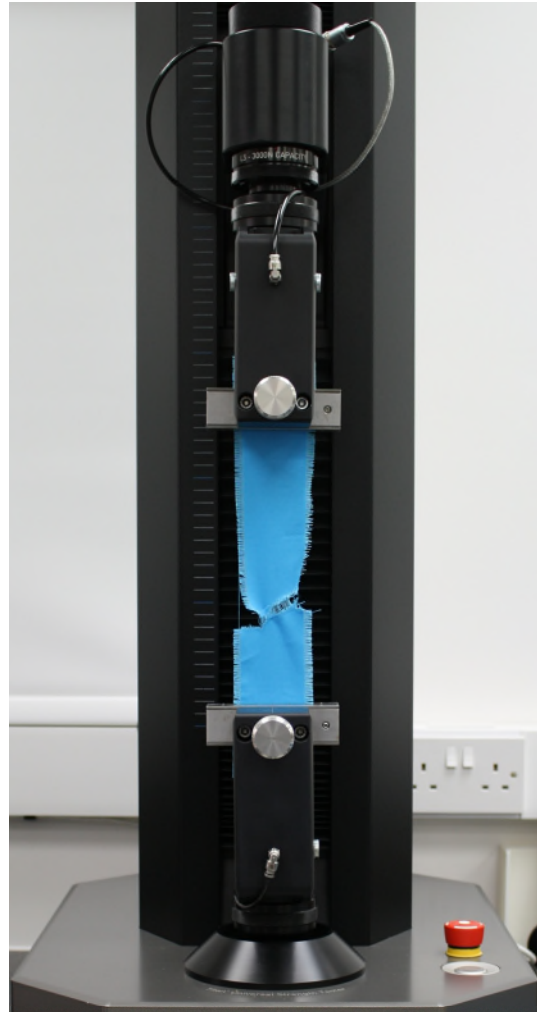

Specimen after testing

When all the specimens have been tested, click View Results in the green bar.

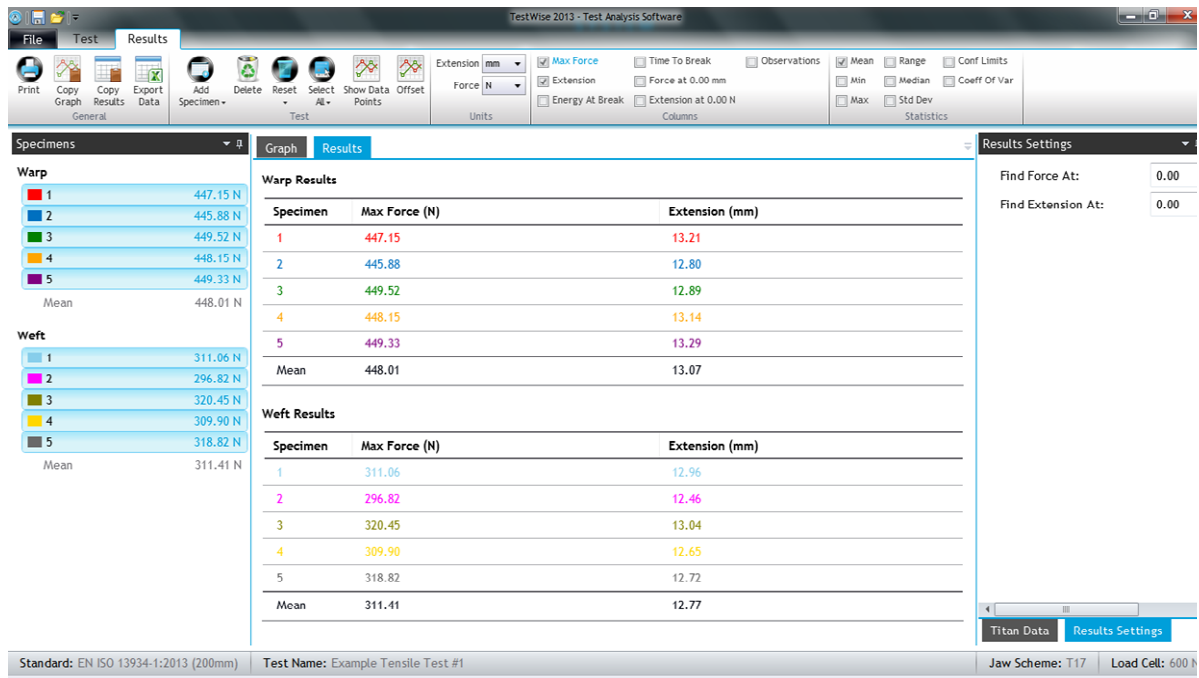

Switch between Results and Graph views.

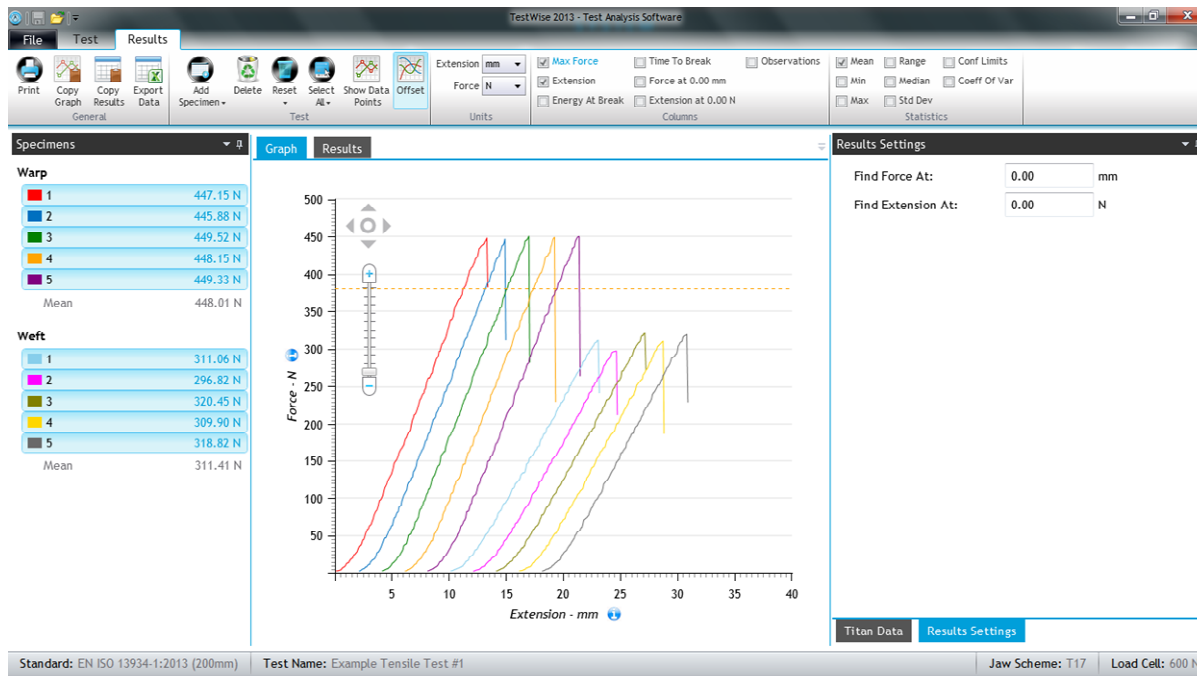

To see a Print Preview, click **Print**.

The Print Preview will show the results and graphs as they are set up in the Results tab.

To print the document, click **Print**.

The screenshot shows the TestWise 2013 - Test Analysis Software interface. On the left, a sidebar contains various menu items: Save, Save As, Open, Close, Info, Recent, New, Standards, Print (highlighted), Options, and Exit. The main window is divided into three sections:

- Print:** A section with a 'Print' button and a 'Print Layout' section.
- Font:** A section with a font dropdown set to 'Trebuchet MS' and a size dropdown set to '10'.
- Header Image:** A section with a checked checkbox and a file path: 'C:\Users\pg\Desktop\Current Projects_I_N!'. There are also icons for image selection.
- Include:** A section with several checked checkboxes: 'Test Details', 'Procedure Settings', 'Results Settings', 'Results', and 'Graph'. An unchecked checkbox for 'Individual Specimen Graphs' is also present.

The main window displays two pages of a test report for 'YOUR COMPANY'. The report title is 'EN ISO 13934-1:2013 (200mm) Textiles - Tensile properties of fabrics - Part 1: Determination of maximum force and elongation at maximum force using the strip method'. It includes test details, procedure settings, and two graphs showing Force (kN) vs Elongation (%). The graphs show multiple curves representing different specimens, with force increasing as elongation increases. The bottom of the window shows 'Page 2 of 2' and search icons.

Fabric – grab test

This example is based on ASTM D5034 using the time-to-break principle. The specimen is approximately 150mm in length and a width of 100mm. An alignment mark is made on the fabric 37-38mm parallel to one of the long sides. The gauge length, or initial jaw separation is typically 75mm.

Search for **5034** and select the “20s” option. This options changes the speed of the test so that the specimens breaks in 20 seconds.

Select the correct Jaw Scheme, in this case T17.
Ensure the 25x25mm jaw faces are in place.
Pretension is not normally used in this test.
Enter sample details.
You can do this later if required.

Change number of specimens and test directions if required. At least 5 specimens in the warp direction and 8 specimens in the weft (filling) direction are required. Click **Start**.

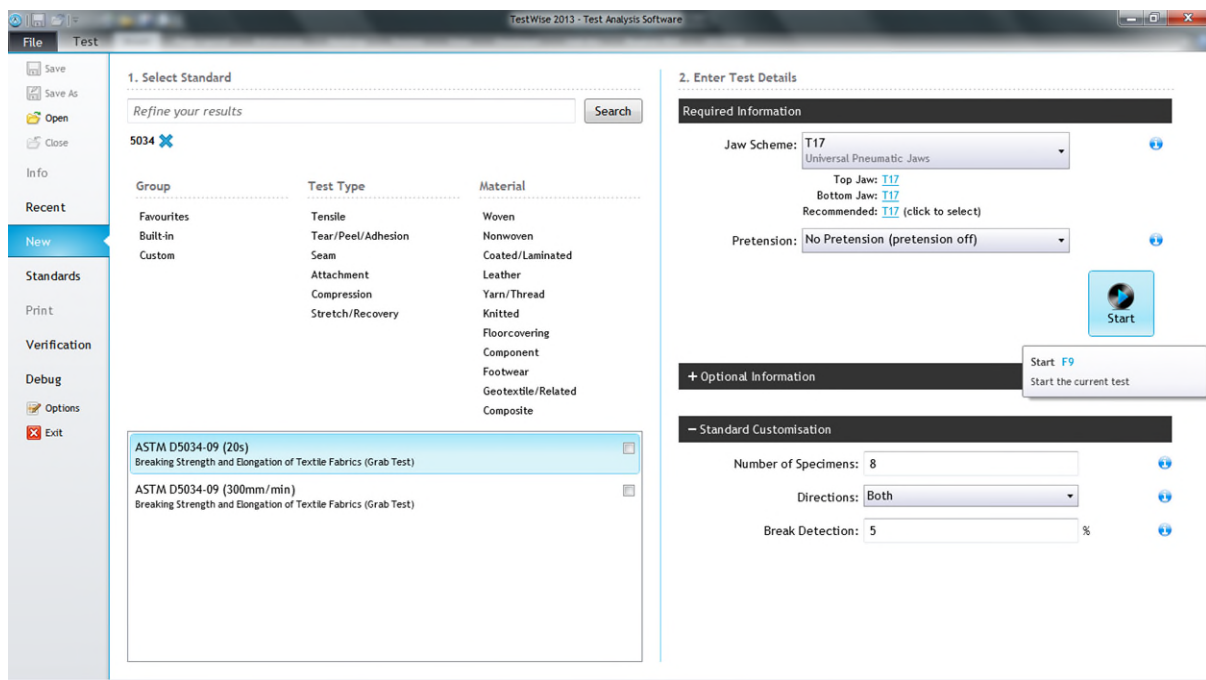

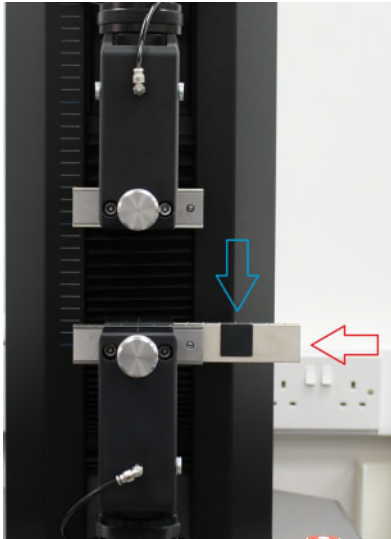

Ensure the 25mm x 25mm jaw faces are inserted.

One only in the top grip and one only in the bottom grip.



Specimen in the jaws ready for testing



Specimen after testing

Additional specimens may be required to establish the correct speed to achieve a fabric break in 20 ± 3 s.

In this example the first warp specimen was broken in 6s at 300mm/min. These results will be disregarded. The speed is recalculated ($6/20 \times 300 = 90$ mm/min). Press Repeat and using a new specimen carry out the test again using the new speed.

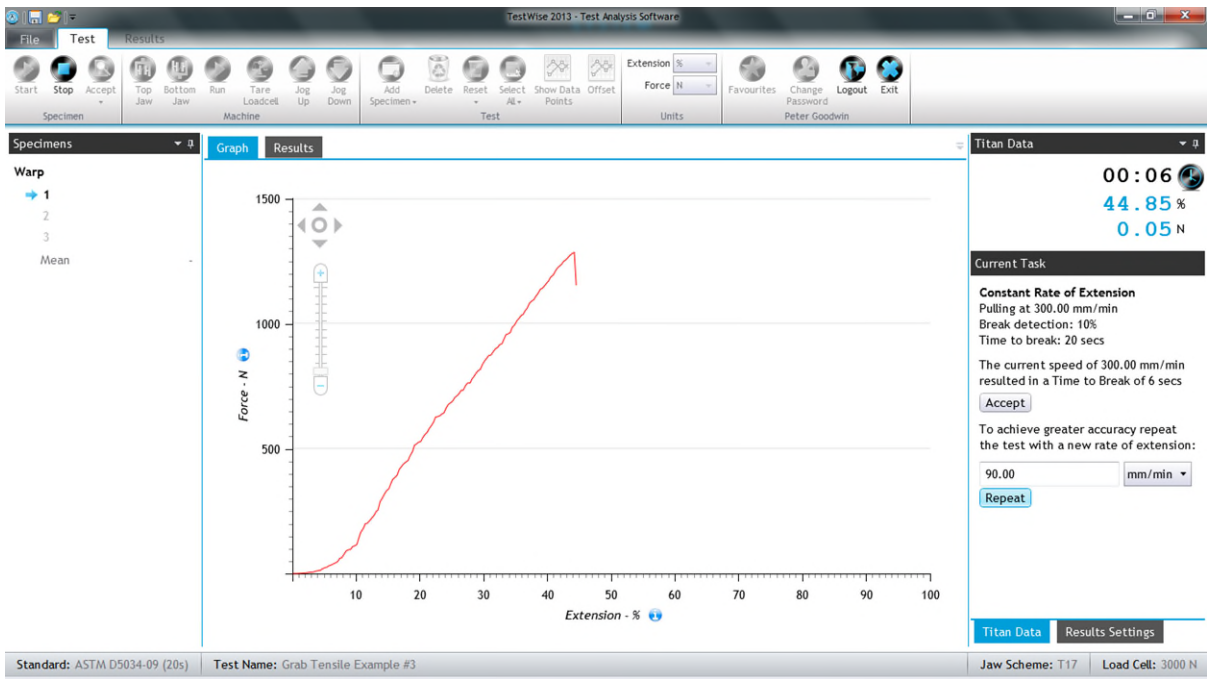

The test is repeated at the new calculated speed.

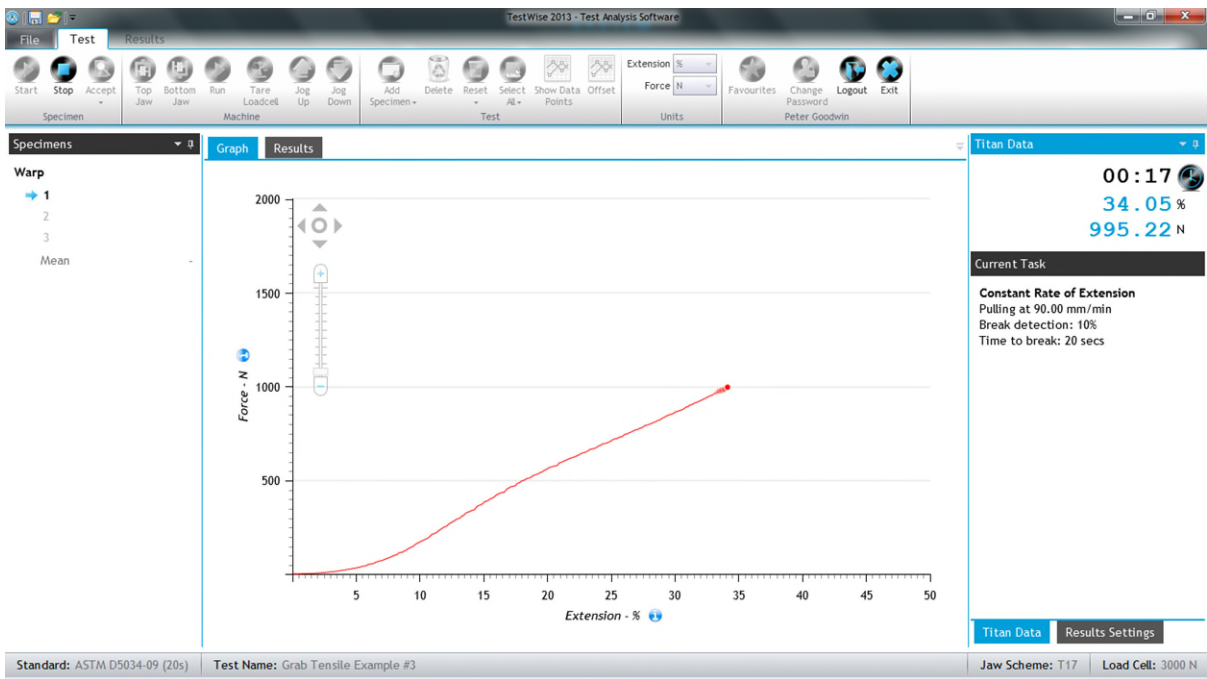

In this case the specimen has broken in 22s.
If the time-to-break is within tolerance (20 ± 3 s) then press **Accept**.

If it is out of tolerance then press **Repeat** again.

Test the remaining warp specimens.
Repeat the process for the weft (filling) specimens.

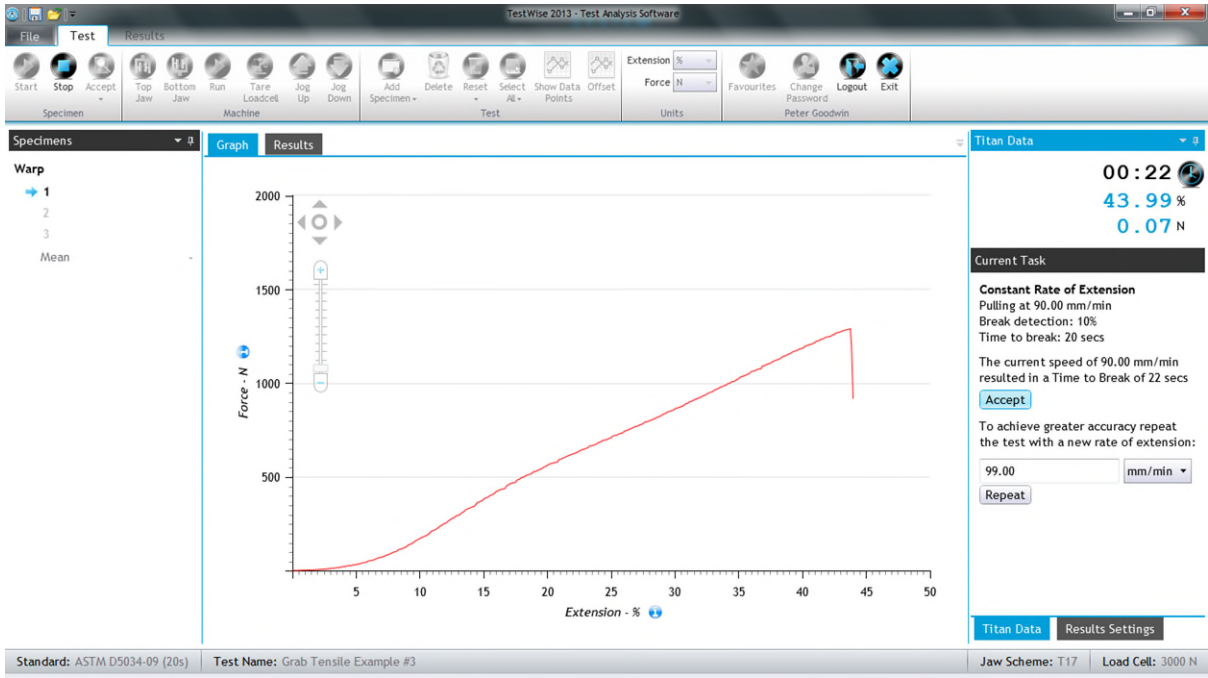

When all specimens have been tested, click View Results in the green bar.

The screenshot shows the TestWise 2013 software interface. At the top, a green bar indicates 'Test Completed' with a 'View Results' button. Below this, the 'Specimens' list shows three specimens with their respective force values: 1 (1287.61 N), 2 (1230.69 N), and 3 (1257.32 N), with a mean of 1258.54 N. The central graph displays Force (N) on the y-axis (0 to 2000) and Extension (%) on the x-axis (0 to 50). A data point is visible at approximately 43.68% extension and 1287.61 N force. The right-hand panel shows 'Titan Data' with values: 484.06 mm and -0.16 N. The bottom status bar includes 'Standard: ASTM D5034-09 (20s)', 'Test Name: Grab Tensile Example #3', 'Jaw Scheme: T17', and 'Load Cell: 3000 N'.

Switch between Results and Graph views.

The screenshot shows the TestWise 2013 software interface with the 'Results' view selected. The 'Specimens' list on the left is the same as in the previous screenshot. The central panel displays a table titled 'Warp Results' with the following data:

Specimen	Max Force (N)	Extension (%)	Time To Break (s)
1	1287.61	43.68	00:22
2	1230.69	42.37	00:21
3	1257.32	43.54	00:21
Mean	1258.54	43.19	00:21

The right-hand panel shows 'Results Settings'. The bottom status bar is identical to the previous screenshot.

Graphs for three warp specimens with offset curves.

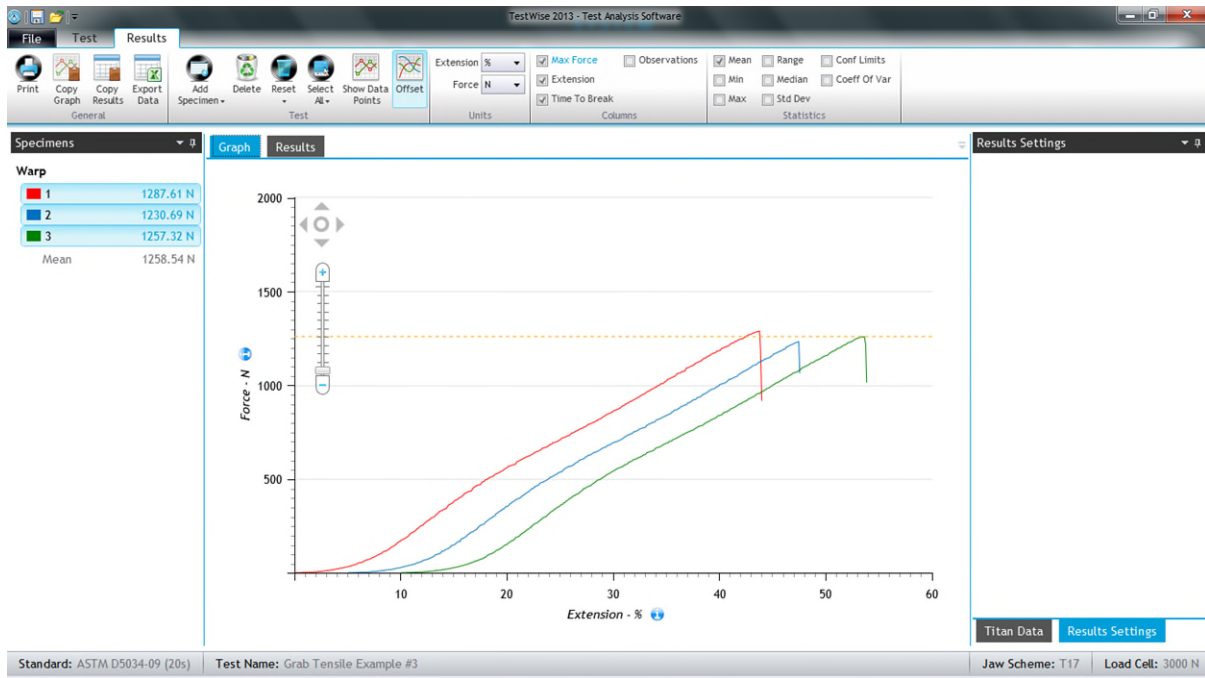

Yarn – Skein / Hank / Lea strength

This example is based on ASTM D1578 Option 2.

Each specimen is a hank (or skein) of 1m circumference and with 100 wraps, i.e., 100m of yarn. This means we are always attempting to break the equivalent of 200 threads simultaneously. For this reason a high capacity load cell is usually required and we recommend starting with the 5000N load cell.



Cotton hank on Skein Spools

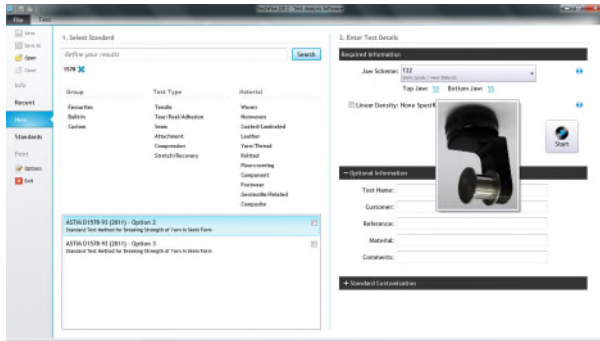

Search for **skein** and select the required option.
Enter the yarn linear density if required.

Enter sample details.
You can do this later if required.

Change number of specimens if required.
Notice this test has no direction.

Click **Start**.

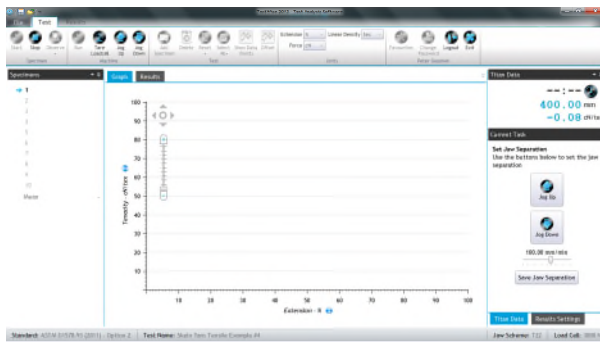

Initially the jaw separation is a nominal 400mm.



Adjust the jaw separation distance so that the hank can be placed on the Skein Spools by using **Jog Up** or **Jog Down** buttons.



When the jaw separation is correct, click **Save Jaw Separation**.

When the next specimen is to be tested Titan will move to this saved position.

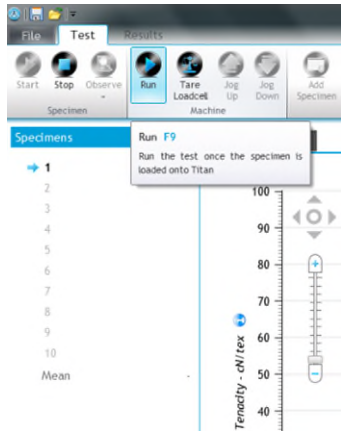

As the Skein Spools are not pneumatic, the Close options are not shown.

Click **Run** or press the F9 function key to start the test.

Notice that because we entered a value for linear density, the force axis now shows cN/tex (tenacity).

If linear density was not entered, then the force units would simply display cN (in this case).

Notice **CSP** in the results screen below, the “Skein Break Factor” or “Count Strength Product” is always the result of multiplying the linear density in English Cotton Count (NeC) by the breaking force in Pounds Force (lbf) regardless of which units of linear density or force were originally used.

Specimen	Skein Breaking Strength (cN/tex)	Skein Break Factor (CSP) (NeC x lbf)	Time To Break (s)
1	1630.20	2164.23	00:22
2	2062.43	2738.06	00:23
3	1694.79	2249.99	00:21
4	2030.77	2696.03	00:24
5	2408.87	3197.99	00:26
6	1756.91	2332.45	00:24
7	1769.69	2349.42	00:25
8	1700.27	2257.26	00:21
9	2357.22	3129.42	00:27
10	2517.83	3342.64	00:25
Mean	1992.90	2645.75	00:24
Conf Limits	±238.29	±316.35	±00:01
Coeff Of Var	16.72%	16.72%	7.73%

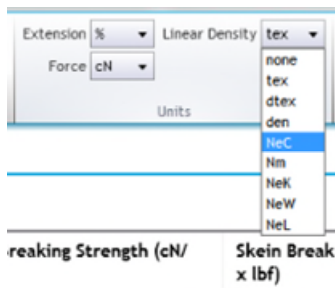

You can change the Extension, Force and/or Linear Density units here if required.

The changes will be reflected immediately in the results.

Fabric Tear – trouser tear test

This example is based on ISO 13937-2.

The specimens are 200mm length and 50mm width.

A mark is placed 25mm from the end to indicate the end of the tear length.

A cut of 100mm is made in the specimens.

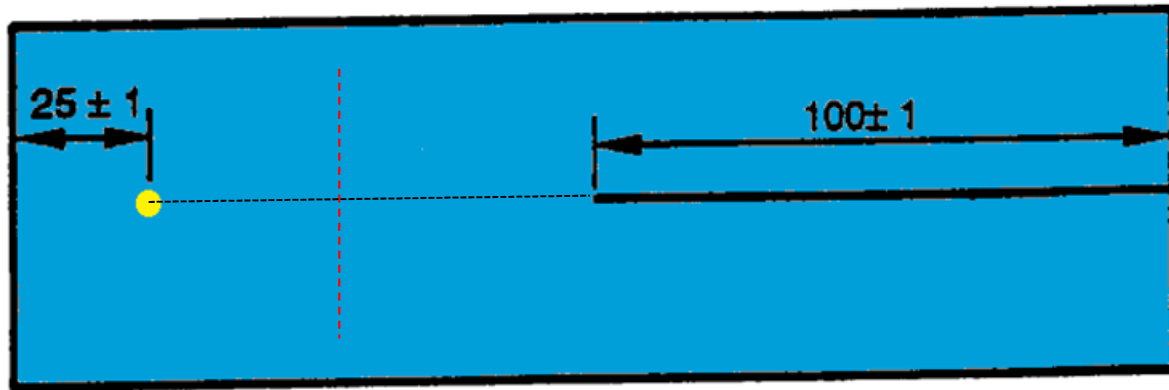

If the red dashed-line in the diagram above is representative of the direction of the warp yarns then this is a warp specimen, i.e., we are tearing across the warp yarns.

During the test we will tear the fabric along the black dashed-line.

Search for **13937-2** and select the required option.

Select the correct Jaw Scheme (T17).

Enter sample details.

You can do this later if required.

Change number of specimens and test directions if required.

Click **Start**.

Group	Test Type	Material
Favourites	Tensile	Woven
Built-in	Tear/Peel/Adhesion	Nonwoven
Custom	Seam	Coated/Laminated
	Attachment	Leather
	Compression	Yarn/Thread
	Stretch/Recovery	Knitted
		Floorcovering
		Component
		Footwear
		Geotextile/Related
		Composite

EN ISO 13937-2:2000
Textiles - Tear properties of fabrics - Part 2: Determination of tear force of trouser-shaped test specimens (Single tear method)

EN ISO 13937-2:2000 (20mm)
Textiles - Tear properties of fabrics - Part 2: Determination of tear force of trouser-shaped test specimens (Single tear method)

EN ISO 13937-2:2000 (auto-stop)
Textiles - Tear properties of fabrics - Part 2: Determination of tear force of trouser-shaped test specimens (Single tear method)

Jaw Scheme: T17
Universal Pneumatic Jaws
Top Jaw: T17 Bottom Jaw: T17

Test Name:
Customer:
Reference:
Material:
Comments:

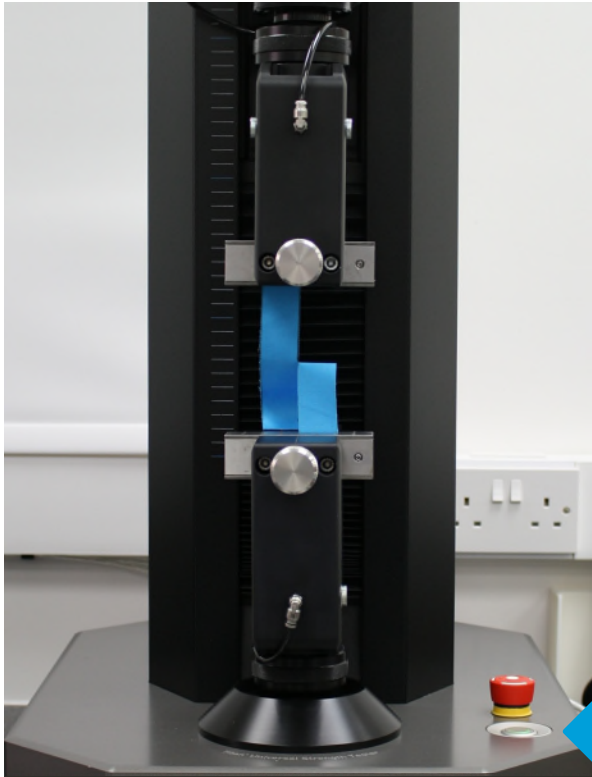

Position the specimen and close the **Top Jaw** and then the **Bottom Jaw**.

Press **Run** to start the test.

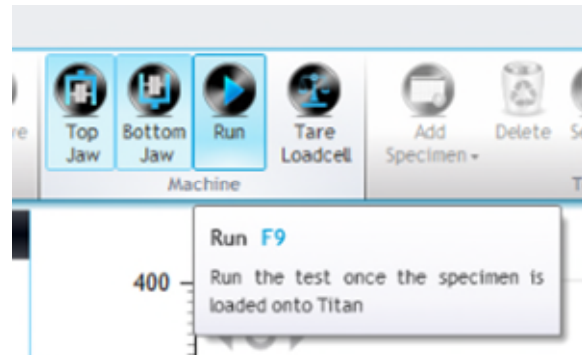

The jaws can be closed and the test started by pressing the Titan button once for each action.

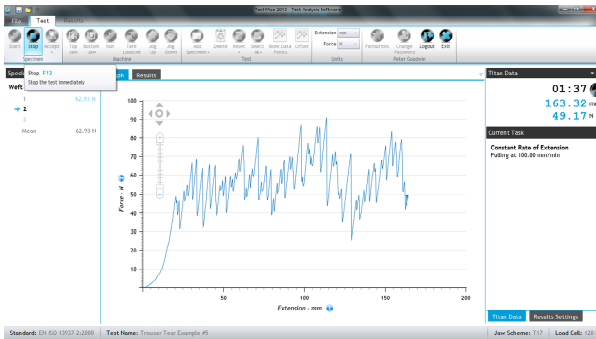

This is a typical graph from a tear test performed on a woven textile fabric.



Observe the specimen as the yarns break. When the tear reaches the mark (25mm from the end of the specimen), click **Stop** or press the F12 function key.

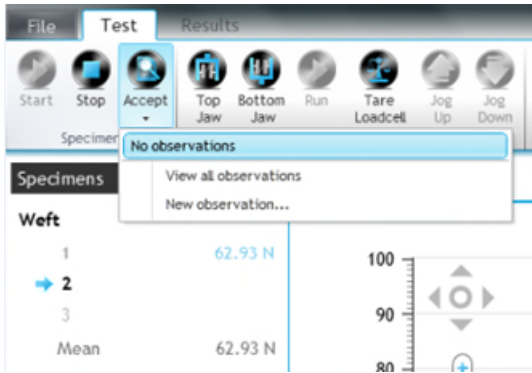

Then **Accept** the specimen data.

To begin the next specimen click **Start** again.



When all the tests have been completed click **View Results**.

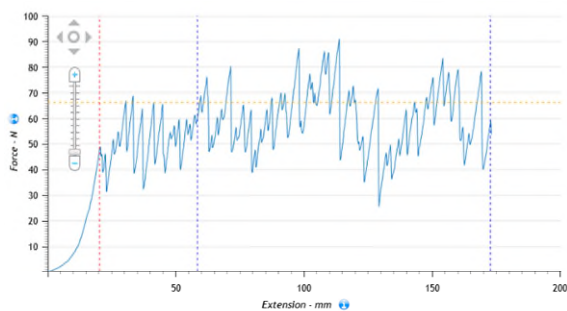

When only one specimen is selected, the graph shows overlays as illustrated here.

The red vertical dashed line is the first peak. The peaks between the first peak and blue vertical dashed line on the left is ignored.

The peaks between the two blue vertical dashed lines is analysed.

When the **View Result** button is clicked, all results are selected and displayed. When viewing multiple tear graphs at the same time it is difficult to distinguish the lines for each specimen even when they have different colours.

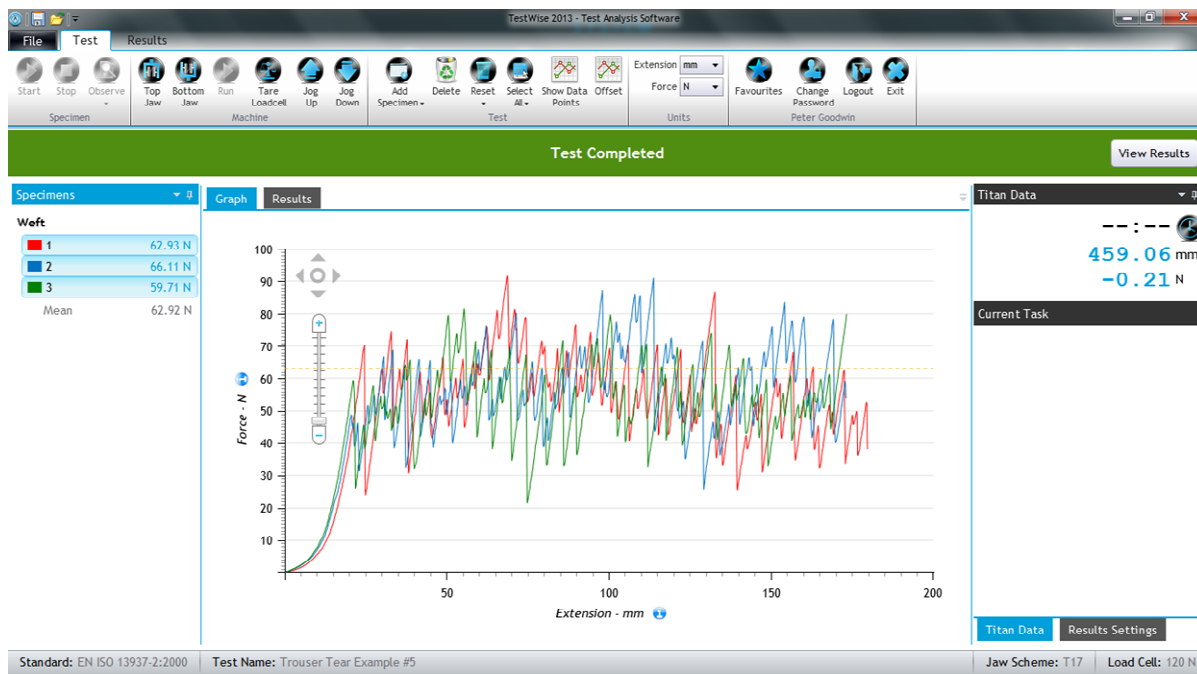

If you do not require graphs in your test report, uncheck the **Graph** option in the Include section. Alternatively, check Individual Specimen Graphs, as shown below.

To print the test report, click Print.

The screenshot shows the 'Print' configuration window in TestWise 2013. The 'Include' section contains the following checked options:

- Test Details
- Procedure Settings
- Results Settings
- Graph
- Individual Specimen Graphs

The preview area shows a test report for 'EN ISO 13937-2:2000' with two specimen graphs. The first graph, 'Web Specimen 1 Graph', shows Force (N) vs. Extension (mm) with a peak force of approximately 80 N. The second graph, 'Web Specimen 2 Graph', shows Force (N) vs. Extension (mm) with a peak force of approximately 60 N. The report also includes a table of Mean Peak Force (N) for three specimens:

Specimen	Mean Peak Force (N)
1	62.92
2	64.11
3	65.71

Fabric Tear – wing-rip tear test

This example is based on ISO 13937-3.

The specimens are 200mm length and 100mm width but have a special shape.

A mark is placed 25mm from the end to indicate the end of the tear length.

A cut of 100mm is made in the specimens.



The lines a-b and c-d are lined up parallel to the edge of the jaw faces.

The test proceeds as per ISO 13937-2.



Fabric Tear – other tests

Other common examples of tear tests are the tongue tear (double-rip) and trapezoidal tear.

Note, if the tongue tear according to ISO 13937-4 is to be carried out then special wide jaw faces are required as shown below.



Tongue tear (or double-rip) tear specimen
ISO 13937-4



Trapezoidal tear specimen
EN 1875-3

Seam Slippage – fixed seam opening method

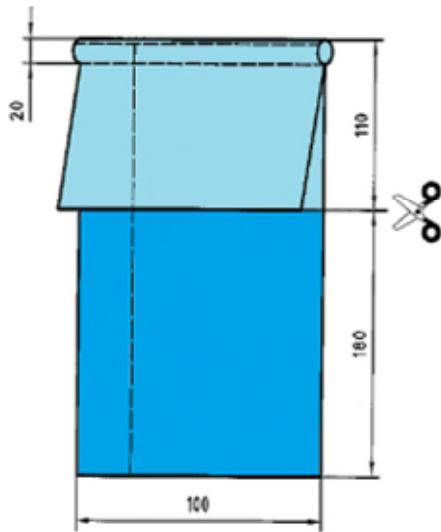

This example is based on ISO 13936-1. The specimens are 400mm length and 100mm width. Other standards may vary in respect of specimen dimensions.

Five (5) specimens in each direction are prepared.

The dashed line is an alignment mark to aid positioning the specimens correctly in the jaws.

Just before testing, the specimen is cut into two (2) parts producing a “seamed specimen” and “unseamed specimen”.

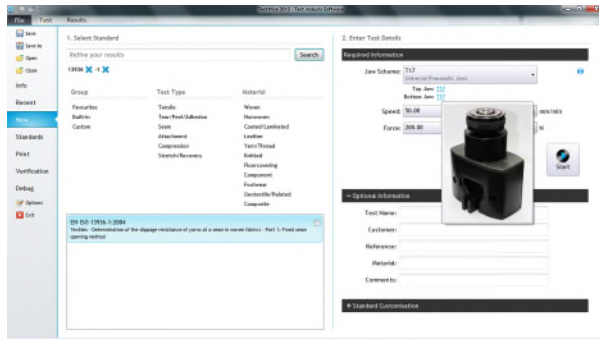

Search for 13936 and select the correct option. Select the correct Jaw Scheme (T17) and fit the 25 mm x 25 mm jaw faces.

Enter sample details. You can do this later if required.

Change number of specimens and test directions if required.

Click **Start**.

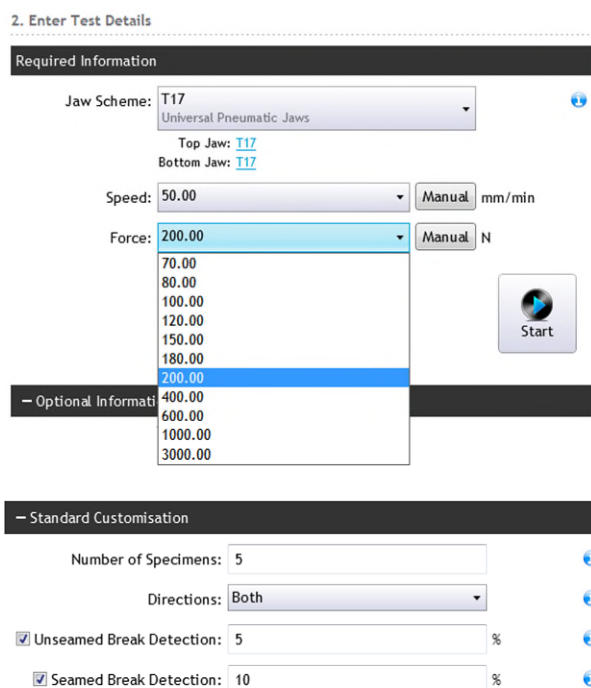

ISO 13936-1 specifies that specimens should be subjected to 200 N.

However, some retailers and buyers have other force requirements and these have been reflected in the drop down list.

If a different force is required then enter this via the Manual button.

Because we have two specimens which react differently to the applied force, two break detection options are provided, one for the unseamed part, the second for the seamed part.

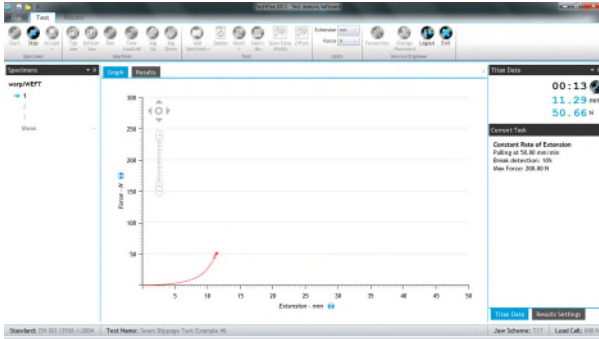

First, clamp the unseamed part of the specimen in the jaws. When clamping ensure no tension is applied to the specimen.

Click **Run**.

When the specified force is reached or a break is detected, the unseamed results are automatically accepted.

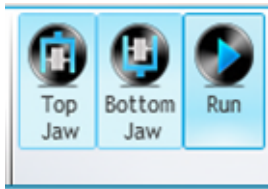

Clamp the seamed part of the specimen in the jaws. When clamping ensure no tension is applied to the specimen.

Click **Run**.

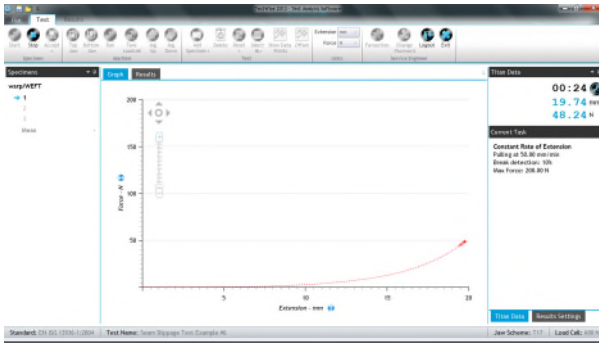

Note that the seamed part is shown by a dashed line as opposed to a solid line for the unseamed part.

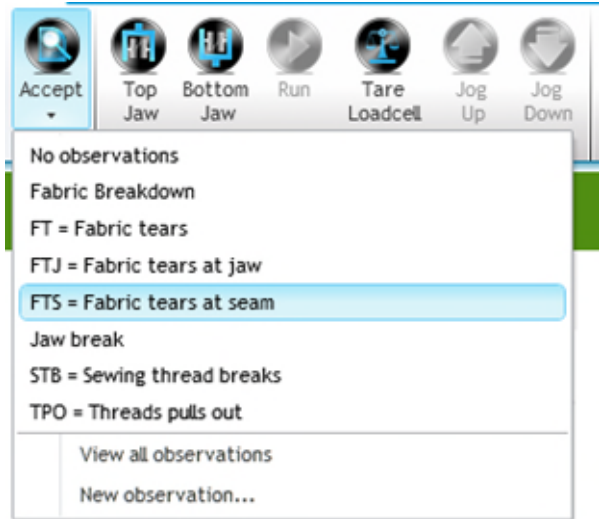

When the specified force is reached or a break is detected, press **Accept**, with or without Observations.

When all the specimens have been tested, click **View Results**. Note that in the **Results Settings** it is possible to change the **Seam Opening Distance**. The default selection is 6mm.

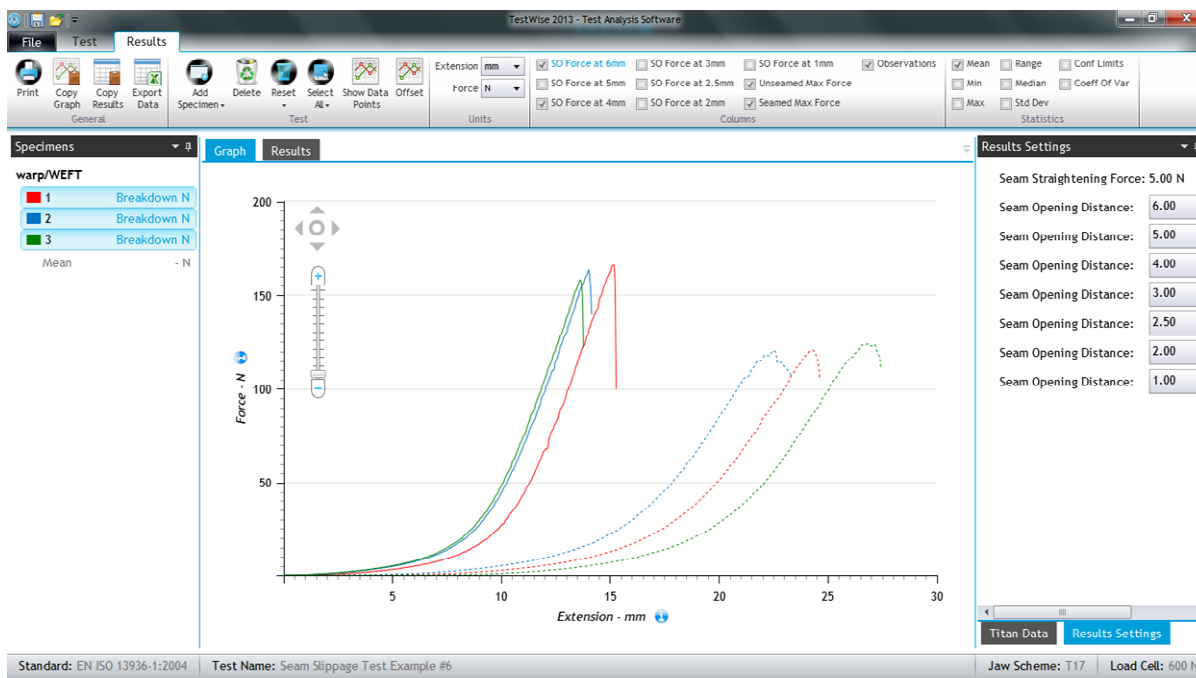
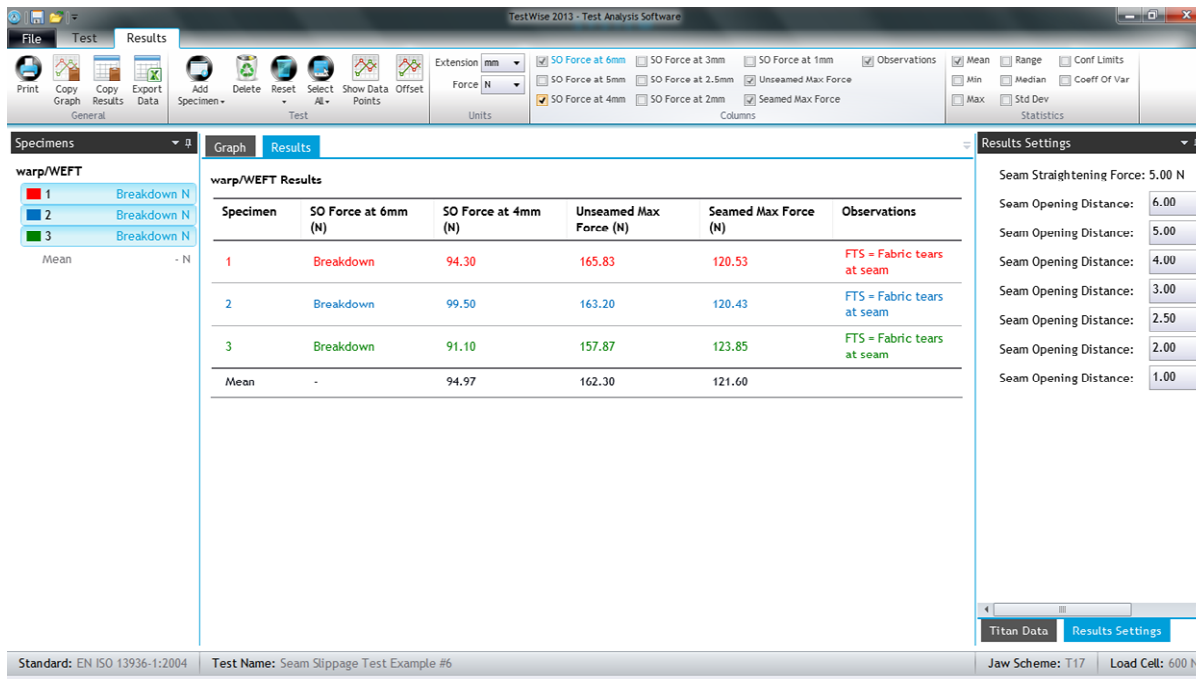

The notation used above, i.e., weft/warp and warp/weft, spoken as “weft over warp” and “warp over weft” can often be confusing. Here are some tips

Weft over warp slippage is defined as movement in the warp direction of the fabric, such that weft yarns move over stationary warp yarns. This means the seam is in the same direction as the weft yarns and the length of the specimen is in the warp direction.

Warp over weft slippage is defined as movement in the weft direction of the fabric, such that warp yarns move over stationary weft yarns. This means the seam is in the same direction as the warp yarns and the length of the specimen is in the weft direction.

Seam Slippage – fixed load method

This example is based on ISO 13936-2.

The specimens are 200mm length and 100mm width. Other similar standards may vary in respect of specimen dimensions. The specimens comprise of one (1) part only, the seamed specimen. Five (5) specimens in each direction are prepared. The gauge length (initial jaw separation) is 100mm.

The user manually measures and inputs the seam opening measurement values.

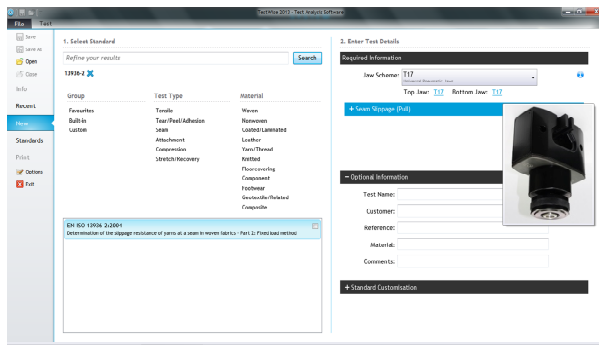

Search for **13936** and select the correct option.

Select the correct **Jaw Scheme** (T17) and fit the 25 mm x 25 mm jaw faces.

Enter sample details.
You can do this later if required.

Change number of specimens and test directions if required.

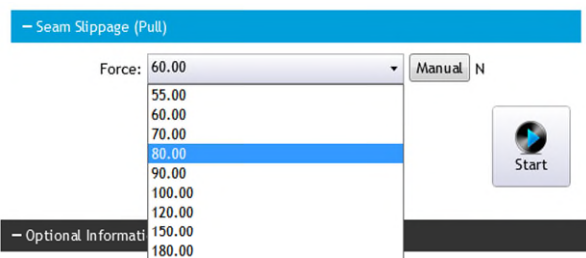

Note there are three (3) popular force values often quoted in specifications. The chosen force depends on the end-use of the article.

Apparel $\leq 200 \text{ gm}^{-2}$	60N
Apparel $> 200 \text{ gm}^{-2}$	120N
Furnishings	180N

Other, less frequently used forces are also listed.

Click **Start**.

Secure the specimen in the jaws with the seam mid-way between and parallel to the edges of the jaws.

For this printed cotton satin fabric for a furnishing end-use, a force of 180N will be applied.



Current Task

Measure Seam Opening

Please measure the seam opening and record the value below. You can also enter the seam measurement later in the results view

Time remaining: 00:10 s

5.0 mm ▼
Save

When the force returns to 5N, you have 30 seconds to manually measure the seam opening distance and enter and save the value.

If you do not enter within this time, note the measurement so that you can enter it later.

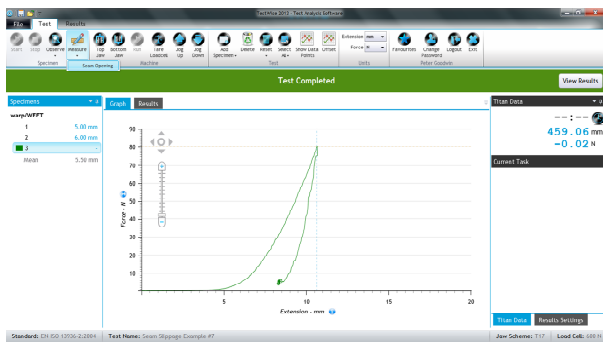

If you need to record any of the manual seam opening measurements, then click Measure-Seam Opening

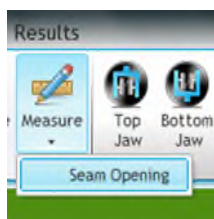

Seam Opening ✕

Units: mm ▼

⬆ warp/WEFT

1:

2:

3:

OK
Cancel

This dialogue box will be presented to you.

Enter the seam opening values if required, followed by OK.

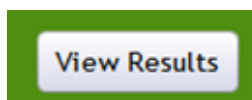

Click View Results

Specimen	Max Force (N)	Seam Opening (mm)
1	80.19	5.00
2	80.13	6.00
3	80.10	4.00
Mean	80.14	5.00

Specimen	Max Force (N)	Seam Opening (mm)
1	80.19	5.00
2	80.13	6.00
3	80.10	4.00
Mean	80.14	5.00

TestWise 2013 - Test Analysis Software

File Test Results

Save
Save As
Open
Close
Info
Recent
New
Standards
Print
Options
Exit

Print

Print Layout

Font
Trebuchet MS 10

Header Image
C:\Users\pg\Desktop\Current Projects_I_N: ...

Include
 Test Details
 Procedure Settings
 Results Settings
 Results
 Graph
 Individual Specimen Graphs

YOUR COMPANY

EN ISO 13936-2:2004
Determination of the slippage resistance of yarns at a seam in woven fabrics - Part 2: Fixed load method

Test Name: Seam Slippage Date: 20/06/2013
Operator: J.P. [unclear] Load Cell No: 0105
Jig Serial: 100-1001 Length: 2.00
Jig Part: 100-1001-001 Part No: 100-1001-001
Load Cell: 400 N

Inspection Format: 400 N
Seam Slippage Path: 400 N
Load: 40.00 N (100%)
Seam Slippage (mm/min): 1.00 N
Inspection Part: 1.00 N
Inspection Time: 20.00

Specimen	Max Force (N)	Seam Slippage (mm)
1	40.15	4.00
2	40.10	4.00
Mean	40.14	5.00

myWET Graph

James Heal Page 1

James Heal Page 1

Page 2 of 2

Stretch & Recovery – line contact

This example is based on EN 14704-1.

The specimens are approximately 300mm length and 50mm width. Other similar standards may vary in respect of specimen dimensions. Five (5) specimens in each direction are prepared. The gauge length (initial jaw separation) is 200mm.

EN 14704-1 describes two (2) methods, Method A and Method B.

Method A uses Line Contact jaw faces and Method B uses Loop Bars (or C-Clamps).

Type **14704** in the search box and select an appropriate option. This examples uses the method described in section 9.1 including a 60 second force decay period.

Select the correct Jaw Scheme (T17) and fit the Line Contact jaw faces.

Enter sample details.

You can do this later if required.

Change number of specimens and test directions if required.

Click **Start**.

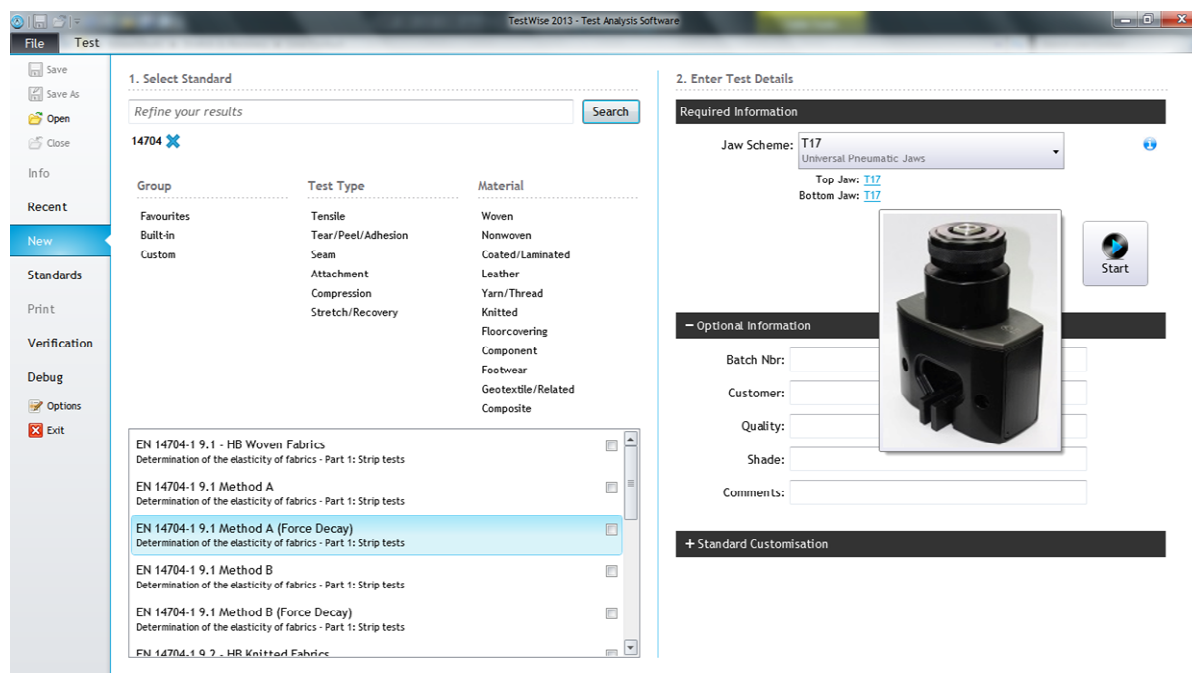

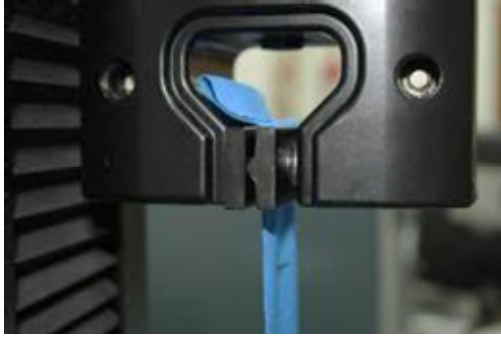

Above: Line Contact jaw faces

Right: Specimen with Gauge Marks



If Recovered Elongation is required, measure the gauge marks at the specified periods. In this example we used 60s (1 minute).

Here are all the weft results and graphs as displayed on screen with an offset. Note that it is possible to change the analysis in the Results Settings section.

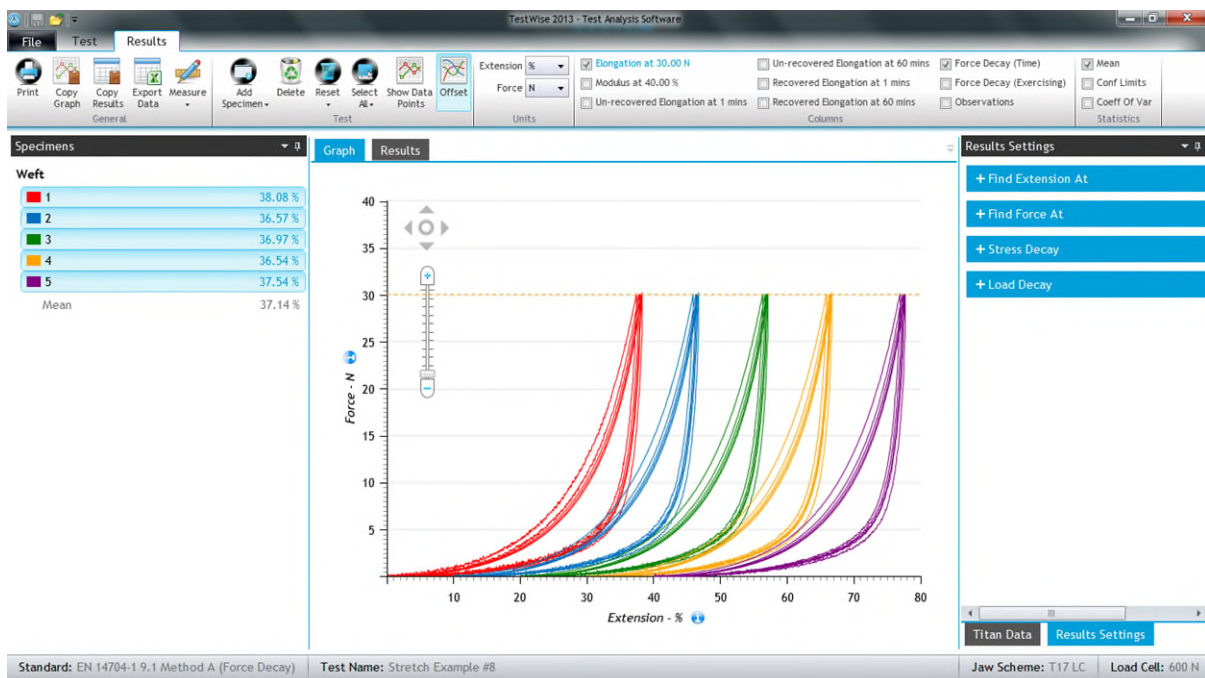
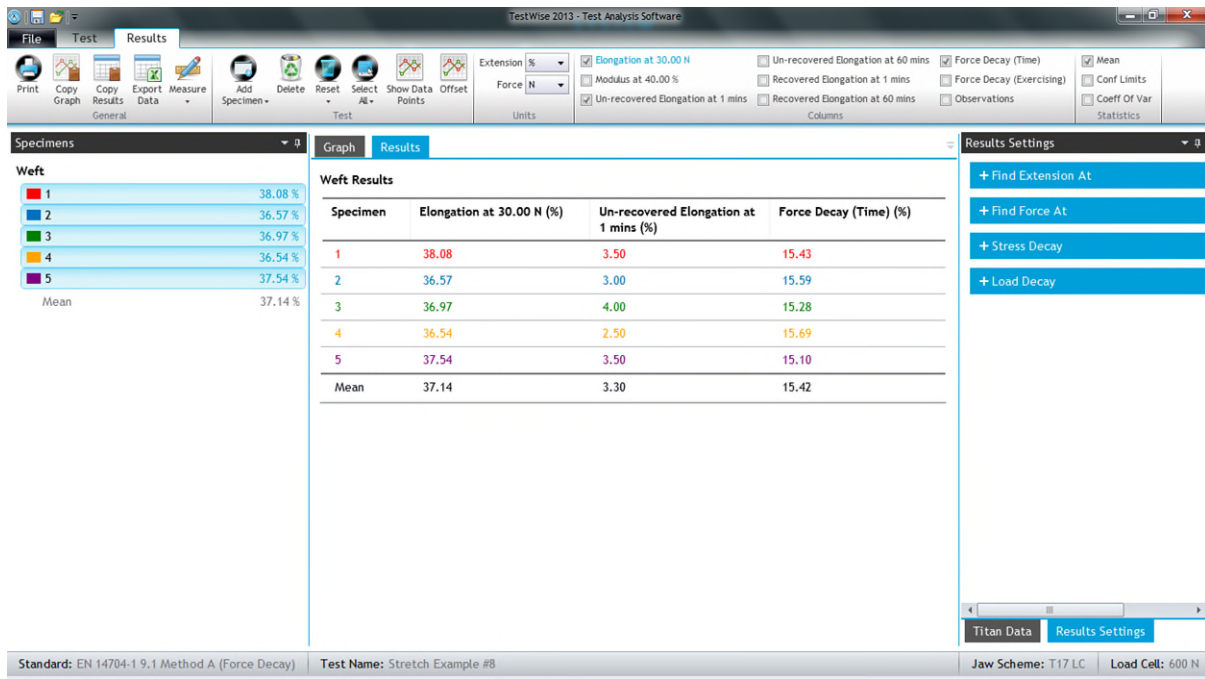

Depending on the elastic characteristics of the specimen and the speed of the test, these procedures can take a lot of time relative to other types of test procedure.

Stretch & Recovery – loop bars

This example is based on EN 14704-1.

The specimens are approximately 250mm length and 75mm width. Other similar standards may vary in respect of specimen dimensions. Five (5) specimens in each direction are prepared. The gauge length (initial jaw separation) is a nominal 100mm, equivalent to the circumference of the loop specimen.

EN 14704-1 describes two (2) methods, Method A and Method B.

Method A uses Line Contact jaw faces and Method B uses Loop Bars (or C-Clamps).

Search for 14704 and select the appropriate option. This examples uses the method described in section 9.2.

Select the correct Jaw Scheme (T18) and fit bars with a diameter between 4mm and 8mm. This example used 8mm diameter bars.

Note we have selected a force of 60N.

Enter sample details. You can do this later if required.

Change number of specimens and test directions if required.

Click **Start**.

The screenshot displays the TestWise 2013 - Test Analysis Software interface. The window is titled "TestWise 2013 - Test Analysis Software" and has a menu bar with "File", "Test", and "Results".

1. Select Standard

Refine your results [Search]

14704

Group	Test Type	Material
Favourites	Tensile	Woven
Built-in	Tear/Peel/Adhesion	Nonwoven
Custom	Seam	Coated/Laminated
	Attachment	Leather
	Compression	Yarn/Thread
	Stretch/Recovery	Knitted
		Floorcovering
		Component
		Footwear
		Geotextile/Related
		Composite

EN 14704-1 9.2 Method A - Fixed Elongation
Determination of the elasticity of fabrics - Part 1: Strip tests

EN 14704-1 9.2 Method A - Fixed Load
Determination of the elasticity of fabrics - Part 1: Strip tests

EN 14704-1 9.2 Method A - Fixed Load (Force Decay)
Determination of the elasticity of fabrics - Part 1: Strip tests

EN 14704-1 9.2 Method B - Fixed Elongation
Determination of the elasticity of fabrics - Part 1: Strip tests

EN 14704-1 9.2 Method B - Fixed Load
Determination of the elasticity of fabrics - Part 1: Strip tests

EN 14704-1 9.2 Method B - Fixed Load (Force Decay)

2. Enter Test Details

Jaw Scheme: T18 8.0mm Bars
Loop Bars

Top Jaw: T18 8.0mm bar Bottom Jaw:
T18 8.0mm bar

Force: 60.00
45.00
60.00
75.00
105.00

— Optional Information

Test Name: Stretch Example #9

Customer:

Reference:

Material:

Comments:

— Standard Customisation

Number of Specimens: 3

Directions: Width

When all specimens have been tested click **View Results**. Here are some typical results and graphs.

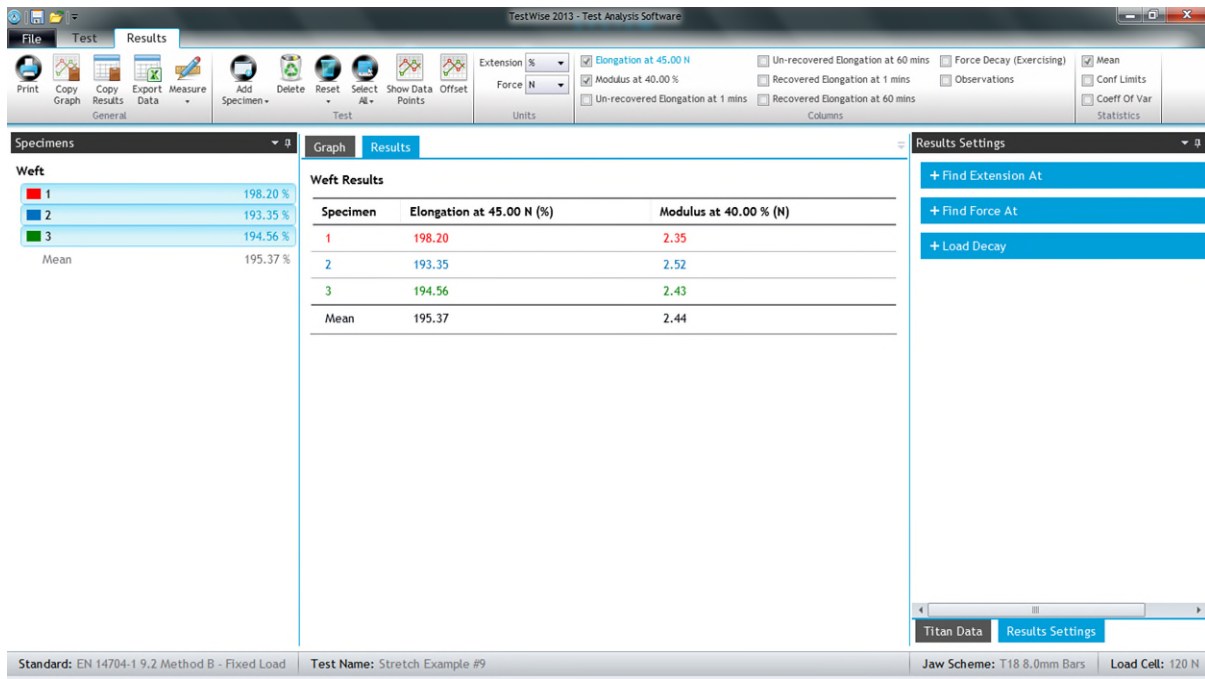

We can see the graph for each specimen more clearly if we “offset” the curves.

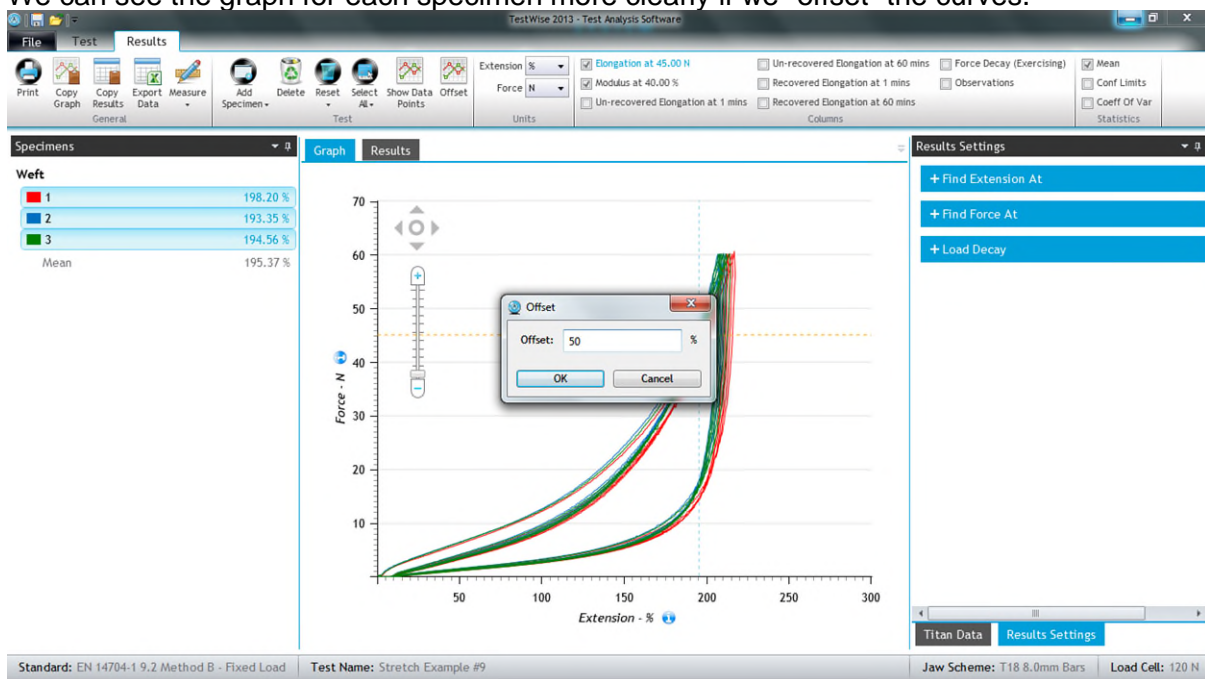

Changing the Results Setting:

You can see that the extension is being determined at 45N. However, we applied a tension of 60N to the specimen and want to find the extension at this higher force.

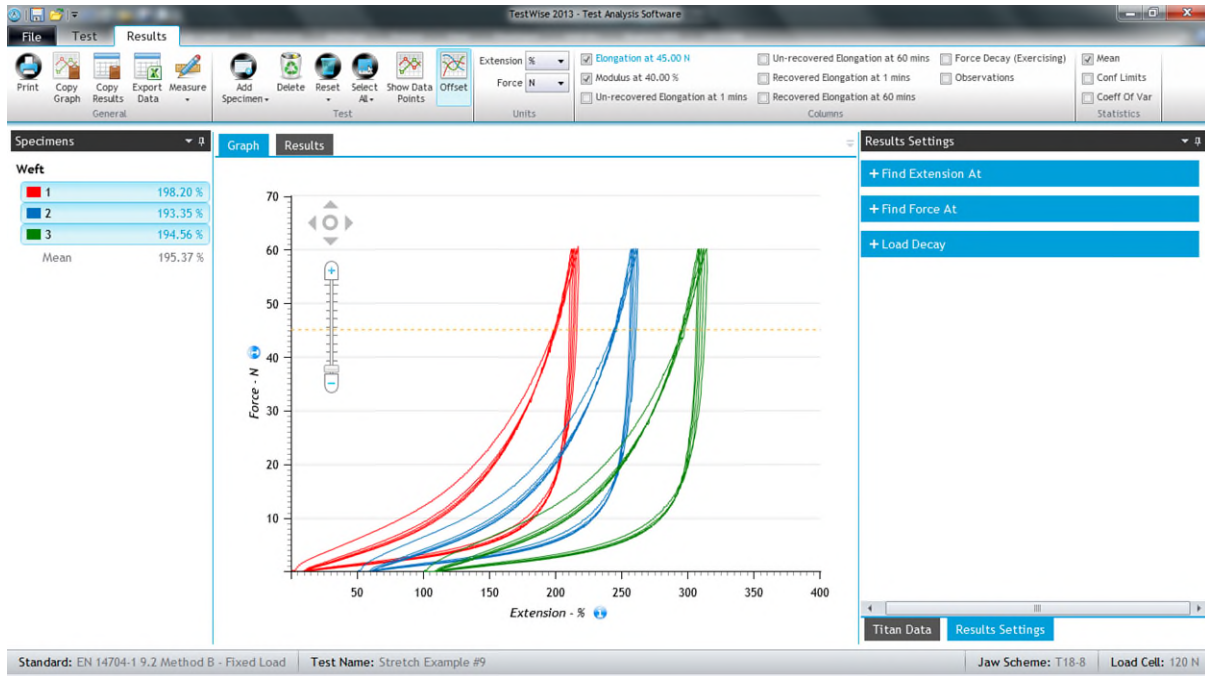

Expand "Find Extension At" Force.

You can see the current setting is 45 N.

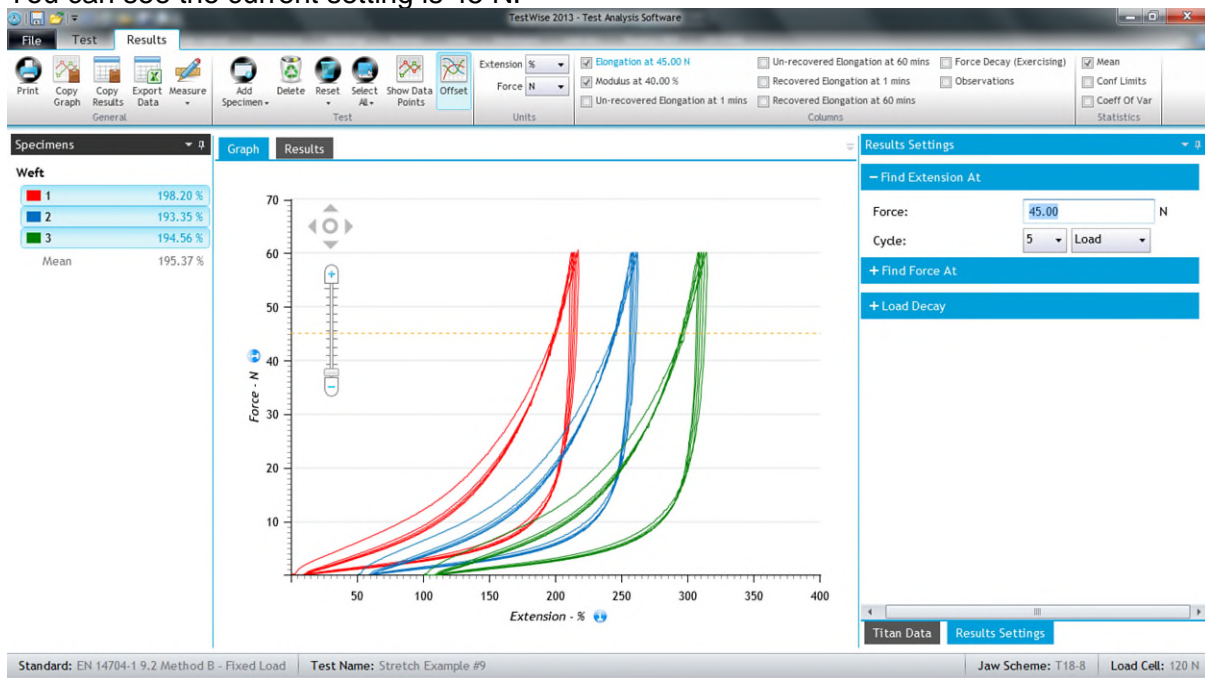

Type in the new value required, in this case, 60N.
 Notice that as soon as you confirm the new value by pressing the enter key, the headings and results are updated.



The Modulus is derived from the “Find Force At” Extension and a typical value is 40%.
 Type a new value if required and press the enter key.

Specimen	Elongation at 60.00 N (%)	Modulus at 40.00 % (N)
1	211.28	2.35
2	206.24	2.52
3	206.89	2.43
Mean	208.14	2.44
Conf Limits	±6.82	±0.20
Coeff Of Var	1.32%	3.34%

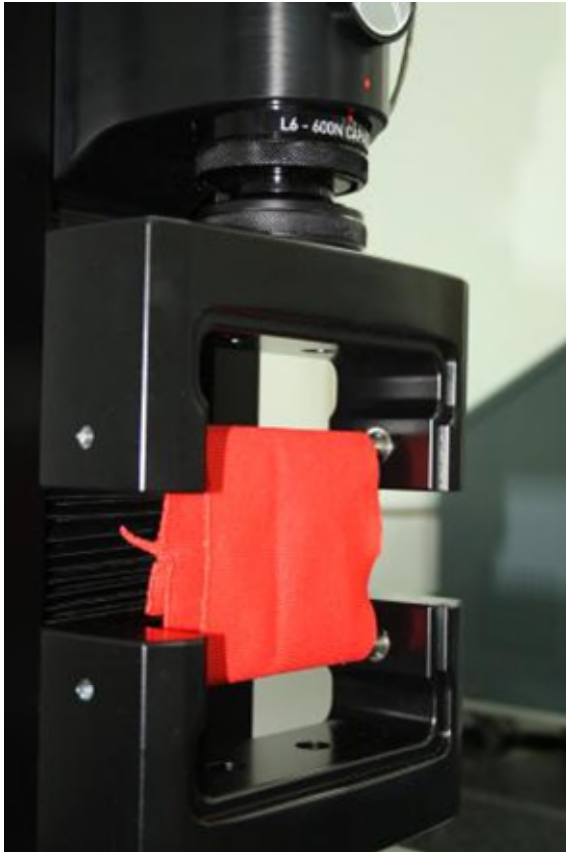

Specimen before testing on Loop Bars

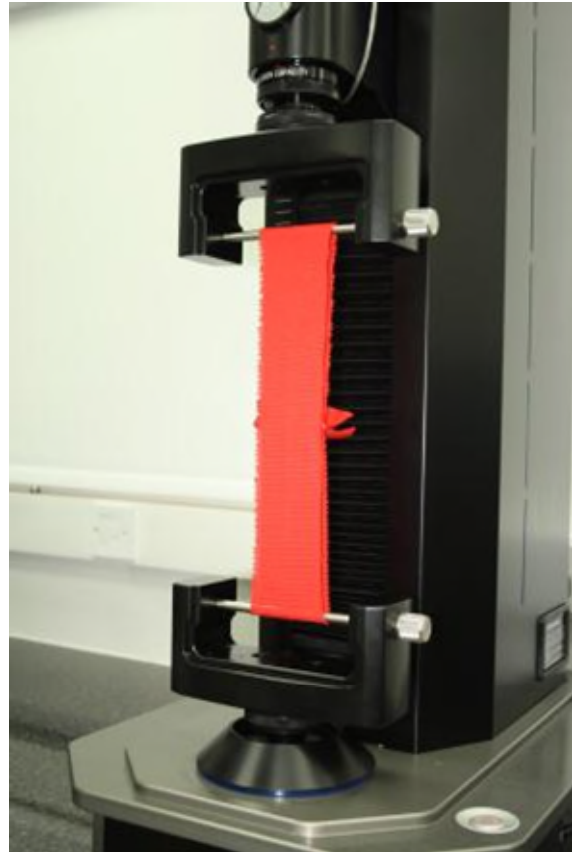

Specimen at maximum specified load

Button Strength

The example is based on BS 4162, but instead of using a welding rod to break the button it uses a strong braided cord. It is the force required to pull a loop of braided cord which has been threaded through two (2) adjacent holes and break the button.

The tooling used is a combination of T17 (to hold the braided cord) and the T4 Button Holder to hold the button.

When using the T4 Button Holder, the button is fully enclosed so that if the button should shatter when broken all of the fragments will be retained.

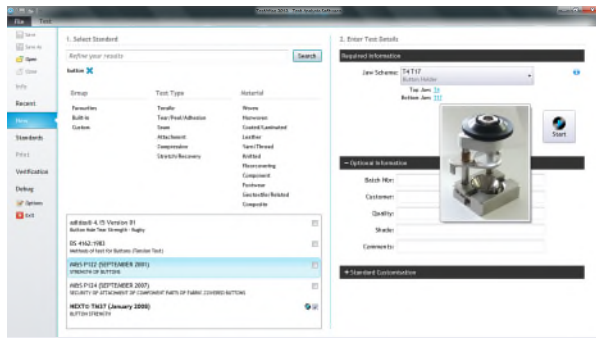

Search for **button** and select the appropriate option.

This examples uses the method described by a popular UK Retailer.

Select the correct Jaw Scheme (T4).

Enter sample details.

You can do this later if required.

Change number of specimens if required.

Click **Start**.

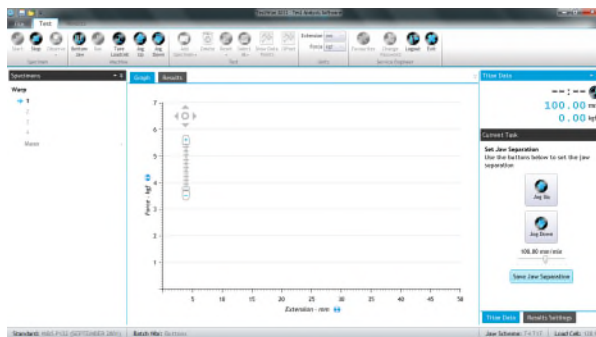

The test will begin with a nominal jaw separation of 100 mm but this can be adjusted to suit individual specimen needs.

Click Save Jaw Separation when a suitable gauge length is obtained.



Button before testing with braided cord attached



Button in T4 and braided cord secured by T17



Button is broken and fragments remain inside T4

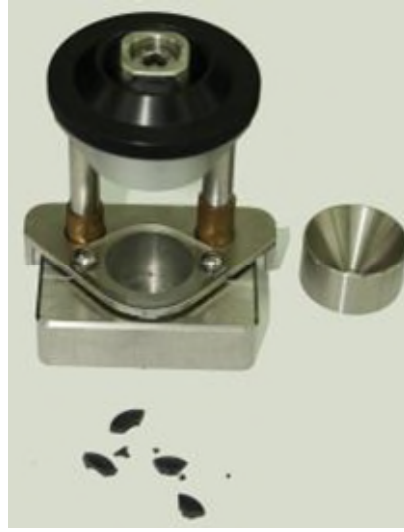

Button fragments removed from T4

These are the results as seen on screen.
The four buttons used were all different, hence the variation in results.

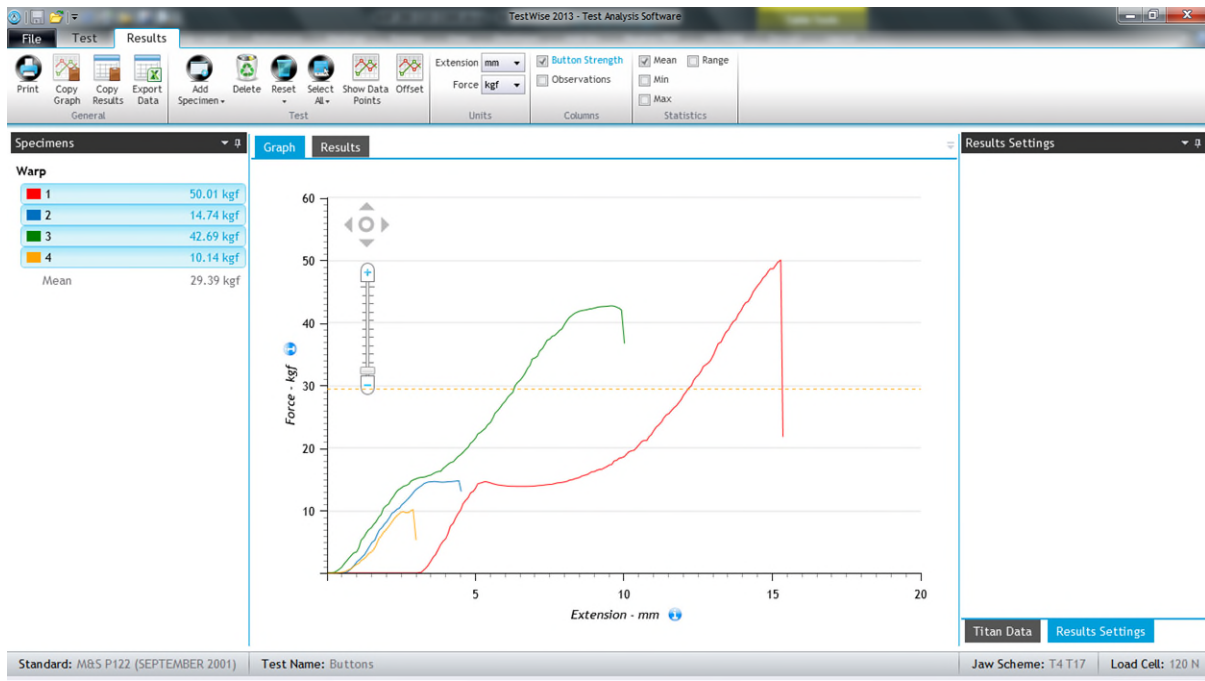

Security of Attachments

The example is based on EN 71-1. It a tension test with three (3) force options: 50, 60 or 90N. This standard was originally designed for the testing of children’s toys but has been adopted for other uses mainly due to lack of alternative standards (although this is slowly changing).

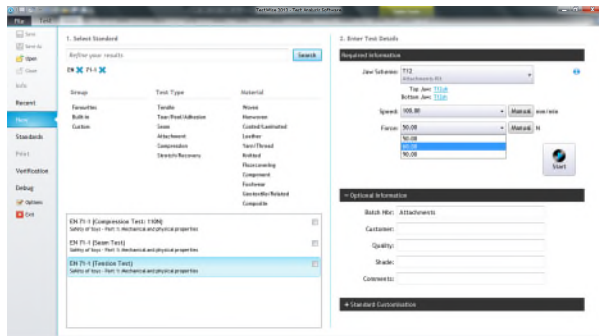

Type **71-1** in the search box. Select the correct Jaw Scheme (T12).

Choice the appropriate force. The choice of speed is dependent on the product under test. EN 71-1 states the force should be applied within 5s, so the speed may need adjusting accordingly.

Click **Start**.



The initial jaw separation is 100mm.

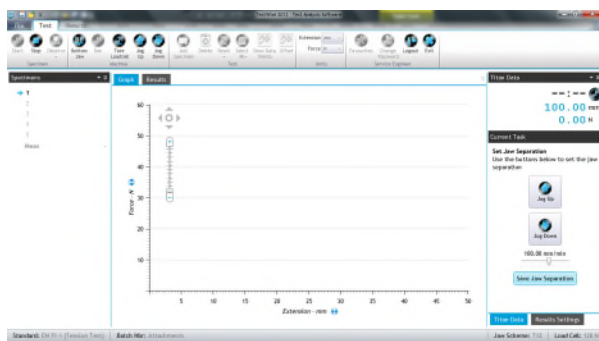

Move the grip to the correct position to hold the attachment and then click **Save Jaw Separation**.

Note that the chosen tooling may vary from that illustrated (three pronged grip) as the tooling is chosen to best grip the attachment.

Here are the results as seen on screen, also showing an observation made on specimen number 4.

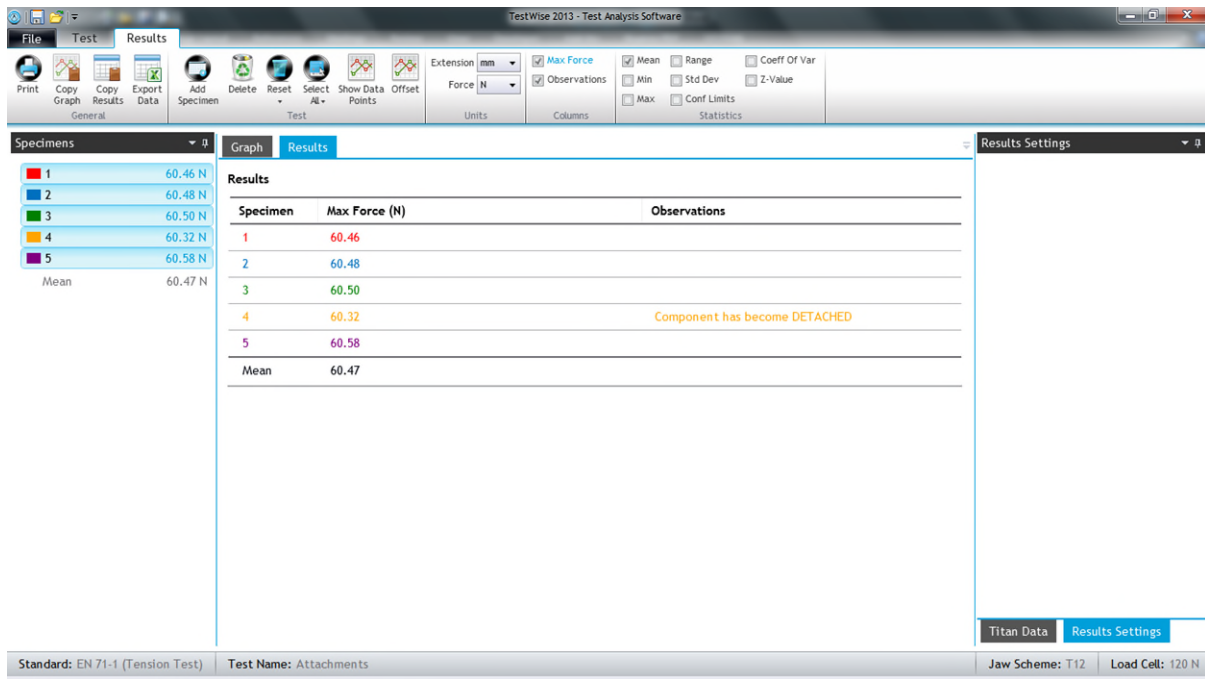

Ball Burst

This is a multi-axial compression test in which a ball is pushed through the specimen and the force required recorded.

This type of bursting test is not as popular as the test carried out on pneumatic or hydraulic bursting strength testers and the results obtained from the ball burst test are not comparable with those from the inflated diaphragm methods.

This example uses ASTM D6797.
The test has no direction.

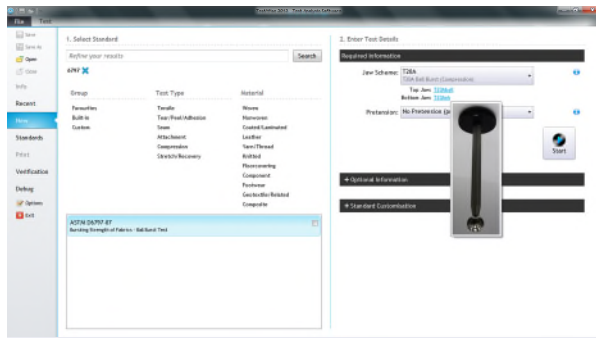

Type 6797 in the search box.
Select the required Jaw Scheme (T20A).
Select the required pretension.

Enter sample details.
You can do this later if required.

Change number of specimens if required.

Click **Start**.



When a compression Jaw Scheme is about to be used, the user is prompted to **Acknowledge** this.

Check that T20A is physically connected to Titan.

This test is very similar to a basic tensile strength test.



T20A setup ready for testing



Specimen after bursting by the ball

Here are the test results as shown on screen.

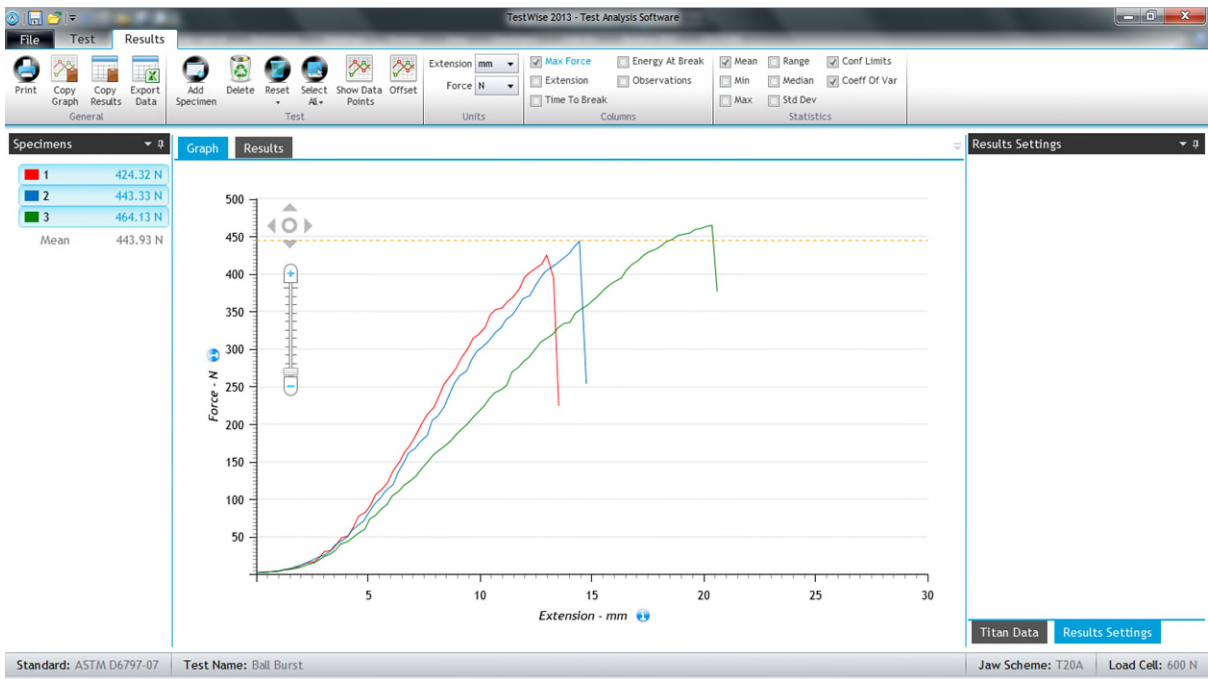
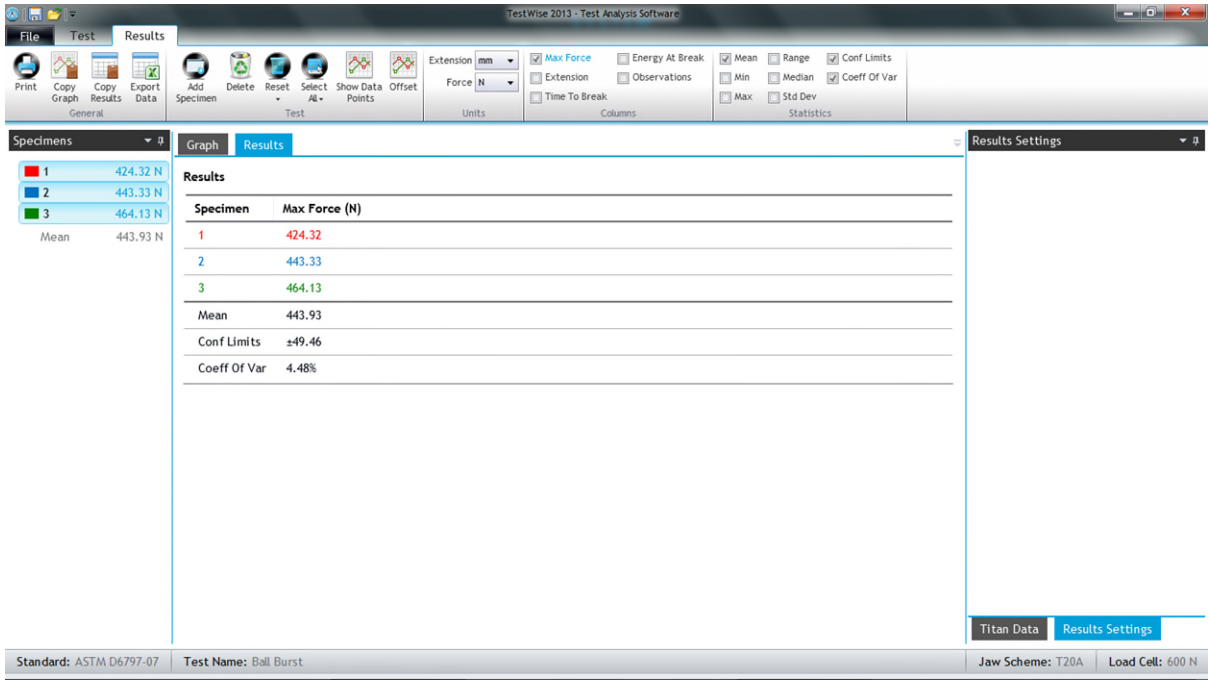

SAFETY

General

Titan has been specifically designed with the Operator's health and safety in mind. This ensures the minimum Operator stress and fatigue. Titan is virtually silent in operation to suit the laboratory environment.

Please observe the following points at all times:

- Take extreme care when moving the machine. Never attempt to manoeuvre Titan without the appropriate lifting gear. Without jaws, Titan weighs approximately 85kg.
- Always remove both hands from the specimen area before starting a test.
- Take care when changing grips and load cell assemblies. Ensure they are always firmly and securely attached to the machine.
- Never place any obstruction in the path of the carriage.
- Always ensure the jaw faces are correctly seated.
- Always ensure pneumatic connections are secure when changing jaws.
- Some materials when tested to rupture can leave the test area either by a whipping action or as fragments. A risk assessment should be made for these types of uncommon materials.

Emergency Stop Button

Familiarise yourself with the location of the large red Emergency Stop Button at bottom left of the instrument. Use this button only in case of emergency to completely stop Titan.

Impact Protection

When the load on an obstruction, such as a hand, equals the weight of the jaw the drive will stop, this will prevent any serious injury. The Operator should, however, always be vigilant and never obstruct the motion of the jaw. If in doubt hit the Emergency Stop Button.

Soft Closing Jaws

Full jaw pressure is automatically applied when the Operator presses the **Start** button. *When loading a sample, only a low pressure is applied*, this will help prevent serious injury. The Operator should, however, always be vigilant and never place fingers between the jaw faces. If in doubt hit the Emergency Stop Button.

UNPACKING

Titan⁵ is attached to a wooden pallet and metal transport frame. These must be removed before use.



Read all of these instructions before beginning to un-pack the instrument.

Before un-packing, transport the box to the room where the instrument is to be located.

Remove the outer top cover to reveal the Accessories Tray.



Remove any additional internal packaging.

Then carefully remove the outer cardboard packaging to reveal the Yellow Transport Frame.



Before moving the instrument, remove the bolts (tools provided) which secure the Yellow Transport Frame to the wood pallet.

With the instrument still lying on its back, lift into the upright position. The 'curved heel' on the bottom lifting frame is designed to ease this lifting procedure.



Once raised into the upright position, the bottom Yellow Transport Frame can be removed from the base by unbolting the front cross member (unscrew the bolts on the left and right as indicated by the red circle).



Then unbolt the remaining left and right sides of the bottom frame from the base of the instrument.

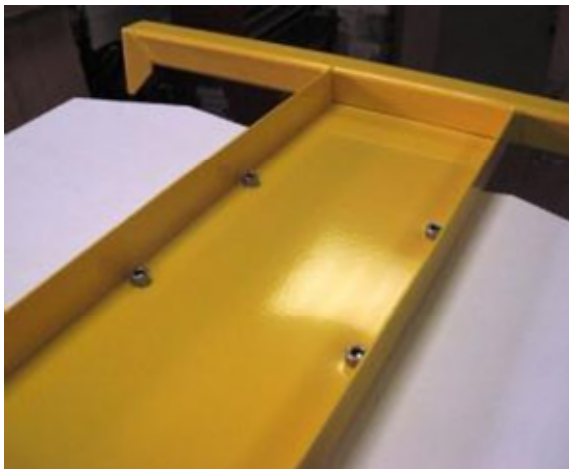

The top Yellow Transport Frame can now be removed from the instrument.

INSTALLATION

Installation Requirements

Desk depth 750 mm recommended, 600 mm absolute minimum.
Desk length 1500 mm to allow for Titan, PC (laptop or desktop style), monitor and printer.

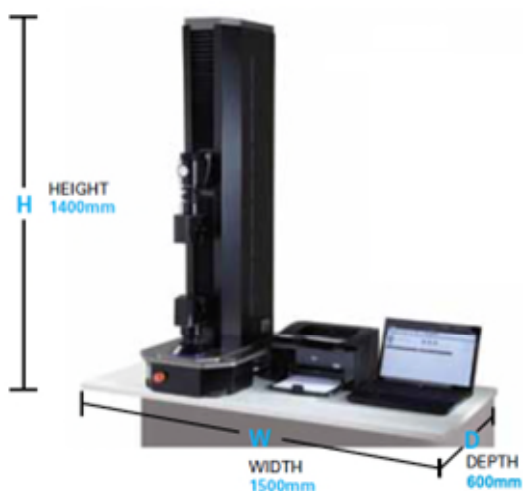

Electrical supply

Machine single phase 110 - 230Va.c. +/-10% at 10A maximum, 50/60Hz, 500W.
Provision must also be made for the PC, monitor and optional printer.

Compressed Air supply



It is recommended the air supply has a minimum Free Air Delivery (FAD) of 11 litres per minute at 8 bar (116psi) and must be filtered to 5 microns (absolute) or better to remove excess particulates, oil and moisture. Minimum air supply 5 bar, optimum pressure 7 bar.

Note: Titan is fitted with on-board filtering. However, a contaminated air supply (not filtered) will result in early blockage of the on-board filter element.

For laboratories without a dedicated compressed air supply, we can offer the choice of an 110V (60Hz) or 230V (50Hz) silent laboratory compressor.

Environment

As with all physical testing, tests should be carried out in a standard atmosphere for testing textiles, i.e., 20°C and 65% RH. However, the instrument will operate satisfactorily providing temperature and humidity levels are relatively stable. The humidity conditions must be non-condensing. The surrounding area should be electrically and magnetically stable.

TECHNICAL SPECIFICATION

Measuring Principle	Constant Rate of Extension (CRE)
Capacity (Tension & Compression)	5000N, 5kN, 500kgf and 1100lbf
Load Cells	5000N, 1000N, 500N, 200N, 100N Quick-change cartridge, auto-recognition “S” beam cells
Test / Return / Jog Speed	1 - 2000mm/min
Accuracy of Load Cells Class	0.5 ($\pm 0.5\%$) from 2 - 100% of load cell capacity
Speed Accuracy	$\pm 0.005\%$
Maximum Stroke	560mm with T27 grips fitted
Total Vertical Space	700mm with no grips fitted
Positional Accuracy	$\pm 0.00125\text{mm}$
Calibration	Load cells: ISO 7500-1 (UKAS accredited) and ASTM E4 Instrument: ISO 7500-1 and ASTM D76
Safety	CE marked (complies with Machinery, Low Voltage and EMC Directives)
Warranty	18 months

TITAN⁵ DIMENSIONS AND WEIGHT

Titan5 is designed to be placed upon on a bench and is recommended the instrument is located within a conditioned atmosphere.

Dimensions (mm)	Height	Width	Depth	Weight (kg)
Titan5	1339	400	500	82*

*Excluding Transit Frame

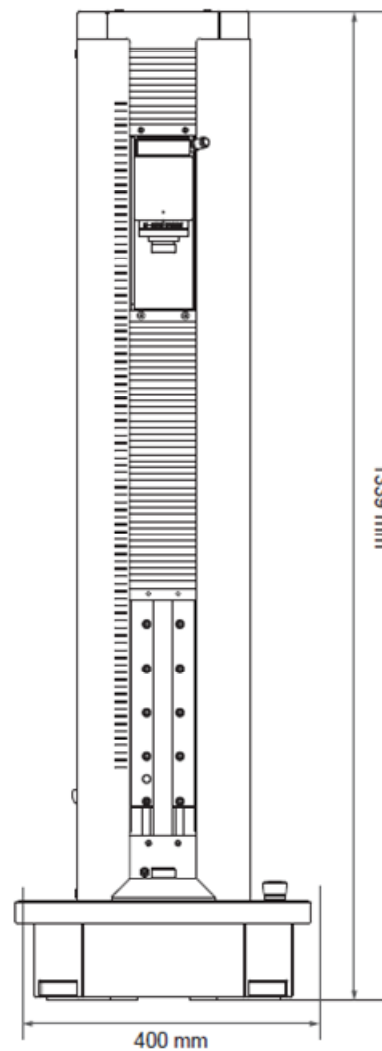
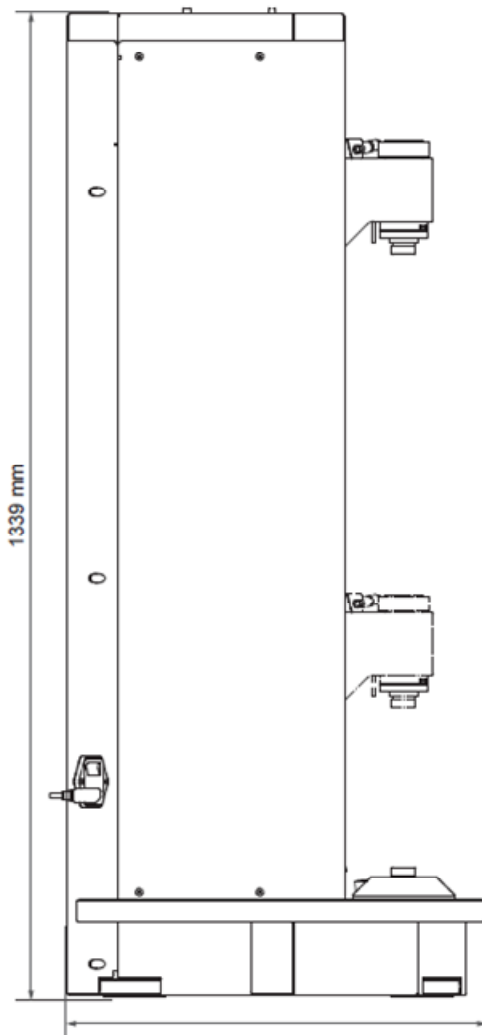
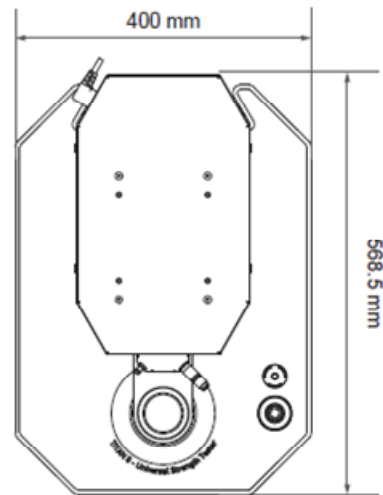

EU DECLARATION OF CONFORMITY



EU DECLARATION of CONFORMITY

In accordance with EN ISO 17050-1:2010

This declaration is issued under the sole responsibility of the manufacturer.

We **James Heal**
of **Richmond Works, Halifax, HX3 6EP, UK**

in accordance to the following directive(s):

2014/35/EU	The Low Voltage Directive
2014/30/EU	The Electromagnetic Compatibility Directive
2006/42/EC	The Machinery Directive

hereby declare that:

<i>Equipment:</i>	Titan 5kN
<i>Models:</i>	1710/05 & 1710/05E Series
<i>Description:</i>	Tensile Strength Tester
<i>Serial Number:</i>	1710/05/YY/XXXX 1710/05E/YY/XXXX
<i>Product Date:</i>	1st Aug 2018

is in conformity with the relevant Union harmonisation legislation, based on the conformity of the following documents:

Applied Harmonised Standards:

<i>Ref. No</i>	<i>Title</i>	<i>Edition</i>
EN 61010-1	Safety requirements for electrical equipment for measurement, control, and laboratory use. General requirements	2010+A1:2019
EN 61326-1	Electromagnetic Compatibility (EMC) equipment for measurement, control and laboratory use.	2013

I hereby declare that the above mentioned product is in conformity with the stated Standards.

AUTHORISED SIGNATORY

Neil Pryke
Innovation Director
DATE: 1st Oct 2019

The technical file is available from our EU Headquarters:

*Neil Pryke
Innovation Director
James Heal
Richmond Works
Halifax, UK
HX3 6EP*

REVISION HISTORY

Rev	Date	Originator	Details of revision
A	15/05/2019	PG	Original release
B	12/12/2019	PG	Added EU Declaration of Conformity
C	29/04/2026	PG	Update to T19 Check Weight Set